



CEN TEK
MARINE

PRODUCT CATALOG

CUSTOM MARINE EXHAUST & VENTILATION SYSTEMS

Engineered to *Outlast* since 1962

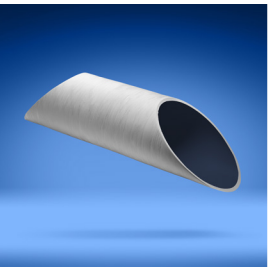

Table of Contents

About Centek Marine	1
.....	
The Centek Marine Engineering Process	2
.....	
Exhaust Systems	5
.....	
Ventilation Systems	29
.....	
Cranston-Eagle Hooks	45
.....	
Warranty	48
.....	

The information contained in this catalog is provided for educational and informational purposes only. While every effort has been made to ensure accuracy and reliability, this catalog may include technical inaccuracies or typographical errors. Centek Marine makes no representations or warranties of any kind, express or implied, about the completeness, accuracy, reliability, suitability, or availability with respect to the information or products provided herein. Any reliance you place on such information is therefore strictly at your own risk. In no event will Centek be liable for any loss or damage arising from the use of, or reliance on, the information provided in this catalog. Centek Marine reserves the right to make improvements, corrections, or changes to the content at any time without notice.

Our History



1962

John Ford creates proprietary formulae and custom designs for marine wet exhaust to balance sound attenuation and performance. Was known as "Vernay Products."



1988

Centek moves its headquarters and manufacturing facility from Ohio to Thomasville, GA, where it becomes the largest manufacturer of fiberglass exhaust systems.



1992

Lynn Oien founds Delta T Systems in Riviera Beach FL to manufacture ventilation systems specifically engineered to withstand the harsh marine environment.



2007

Bill Hodges acquires Centek and becomes CEO. Hodges and partners Bill Arwood, Ken Harstel, and Jeff Fortner usher in a new era of growth for Centek.



2008

After two decades of marine industry experience, Johan Hagstrom opens up what will become known as Viking Marine Exhaust and becomes a renowned fabricator of metal risers for marine exhaust.



2021

Centek acquires Delta T Systems, which has grown to be the world leader in marine ventilation systems. Centek adds a second facility and moves ventilation manufacturing to its Thomasville headquarters.



2023

Centek acquires Viking Marine Exhaust and adds metal riser fabrication, making Centek the premier full engine room exhaust and ventilation provider for vessels across the globe.

Our Engineering Process

Built upon a 60+ year history, the name Centek has become synonymous with quality for naval architects, refitters, and boat builders across the globe. Our experienced engineering team designs, on average, one new product every single day. Today, this catalog contains thousands of parts; each design began as a custom engineered part, and this continues to be our specialty.

If you do not see what you need, our experienced team can engineer a custom system to meet your specifications. While the parts are different, our engineers typically follow a similar process, which has been refined over the past 60 years.

With our best-in-class, CAD technology and proprietary formulae, we can design any marine exhaust or ventilation system to best meet your needs.

Our engineering team has over 150 years of combined experience designing custom engine room exhaust and ventilation systems that are currently on vessels throughout the world.



Discovery

When you call or email Centek Marine, our expert Customer Service Relations (CSR) Team stands ready to help. If you require a standard part, they can process the order.



Consultation

If your need is custom, the CSR team will put you in touch with one of our engineers.



Information Gathering

Our engineers will ask a series of questions, including engine make and model, power, maximum back pressure and dimensions of the area allocated.



Design & Approval

Once our engineers have all the information they need, they will create your custom system(s). After you sign off on your design, you can place a PO.



Manufacturing

After a PO is received, it is manufactured right here in our facility. Our CSR team will communicate with you throughout the process on the expected timeline.

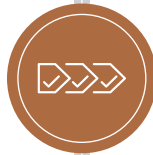

Quality Assurance

All products are tested for form, fit and function in accordance with our quality mandate.



Ongoing Support

Once you receive your product, our engineers stand ready to support you and ensure a seamless installation.

Certifications + *Memberships*

CERTIFICATIONS

Lloyd's Register Type Approved for fiberglass products

American Boat & Yacht Council (exceeds guidelines for wet exhaust systems)

International Organization for Standardization ISO Certification

*Copies of Certifications are available upon request

MEMBERSHIPS

National Marine Manufacturing Association (NMMA)

Marine Retailers Association of America (MRAA)

Association of Marina Industries (AMI)





Exhaust Systems



Within an engine room, Centek Marine offers both exhaust and ventilation systems.

The primary purpose of a marine engine room exhaust system is to safely move combustion by-products out through a tight space as efficiently as possible without creating too much backpressure. Centek Marine's line of ventilation products bring in the proper amount of air so that your engine(s) operate at peak performance. Centek Marine exhaust products support that performance and effectively balance the backpressure requirements of the engine and desired sound attenuation.



Wet exhaust is the process in which the cooling water is injected into the exhaust line, reducing both the temperature of the gas along with the accompanying fumes. Wet exhaust systems have the advantage of using the heat-absorbing and sound-dampening qualities of water to cool and quiet the exhaust. It also transports raw water or sea water and protects the engine against water entry. Centek Marine offers both propulsion and generator exhaust. With propulsion exhaust, gases directly from the engine reaching up 1,000 degrees Fahrenheit are carried in a metal riser and injected with cooling water. The cooled water then goes into a muffler that is specifically engineered to attenuate the sound produced by the engine while balancing backpressure allowances specified by the engine manufacturer.

Generator wet exhaust systems connect with the generator and can be installed below, at, or above the waterline.



Our exhaust systems work for both diesel and gasoline engines, and we have a complete database of nearly every major engine manufacturer. Our proprietary formulae, which have been developed and refined over the past 60 years, will deliver optimal product performance while ensuring that the maximum power output of the engine is not negatively impacted.



While this robust catalog contains of thousands of parts, Centek Marine's specialty is in custom parts. If you do not see what you need, scan this QR code to fill out a form that will go to our engineering team.

You may also reach out to our engineering team at +1 229.228.7653 or info@centekmarine.com so we can help you design the optimal system for your vessel.

Why use fiberglass reinforced plastics to make wet marine mufflers? FRP will not corrode or deteriorate when exposed to gasoline or diesel fumes mixed with salt or fresh water. Electrolysis and welds in stainless steel, which will often cause failure, are eliminated. Resistance to higher temperatures will not result in warping or melting often observed in some rubber or plastic mufflers. The right mufflers should be determined based on the *desired level of noise reduction, application, engine location, engine size, and space allotted for the exhaust system.* Please see the summary chart for all mufflers and their characteristics.

Product Family	Product	Sound Attenuation		Application	Waterline
	Minimax	Fair	10-12 dB	All inboards (best suited for smaller applications such as V-Drives)	Above Only
	Vernaski [^]	Good	15-18 dB	All Inboards (best suited for smaller applications such as ski boats)	
	Vernatone Round (all configurations)	Good	15-18 dB	All Inboards	
	Vernatone Oval (all configurations)				
	Vernatone MK II Round	Better	22-28 dB		
	Vernatone MK II Oval				
	Vernatone MK II Dual Stage Round	Best	25-30 dB		
	Vernalift Top In / Top Out	Better	22-28 dB		Inboards, Sailboats & Generators
	Vernalift Side In / Top Out				
	Vernalift Inline				
	Vernalift Side Angle In / Top Out				
	Vernalift Compact Side In / Top Out				
	Vernalift Compact Top In / Top Out				
Vernalift Dual Stage	Best	25-30 dB	All Inboards	Above Only	
	Gen-Sep	Best	25-30 dB	Generators (must be used in conjunction with a Vernalift)	Above Only
	Combo-Sep Vertical	Best	25-30 dB	Generators and Inboards	Above Only
	Combo-Sep Horizontal				
	Underwater Exhaust Vertical	Best	25-30 dB	Inboards	Above Only
	Underwater Exhaust Horizontal				

[^]Vernaski is for gas engines only; all others are compatible with either gas or diesel engines

Engine Horsepower 0-500 HP	Typical Exhaust Size
0-10	1.50 - 2.00"
11-25	1.75 - 3.00"
26-50	2.00 - 4.00"
51-75	2.50 - 4.00"
76-100	3.00 - 4.50"
101-125	3.50 - 5.00"
126-150	3.50 - 6.00"
151-200	4.00 - 6.00"
201-225	4.00 - 8.00"
226-350	5.00 - 8.00"
351-500	6.00 - 10.00"

Engine Horsepower 501-6000+ HP	Typical Exhaust Size
501-550	8.00 - 10.00"
551-675	8.00 - 12.00"
676-925	10.00 - 12.00"
926-1200	12.00 - 14.00"
1201-1750	12.00 - 16.00"
1756-2300	14.00 - 18.00"
2301-2700	18.00 - 20.00"
2701-3500	18.00 - 24.00"
3501-6000	24.00 - 26.00"
>6000	Call Centek

*Tables are for general reference only; please contact Centek Engineering for your specific engine or generator.



Vernatone®

The Vernatone® family of inline exhaust mufflers are the *original* Fiberglass Reinforced Plastic (FRP) water-cooled marine mufflers and have been synonymous with inline mufflers for over 60 years. The FRP design attenuates sound and prevents *catastrophic* failure during short periods of water loss. As the industry has evolved, so has Centek's Vernatone® product line. Collaboration with naval architects and engine manufacturers has resulted in hundreds of variations already available in our catalog for nearly all engine makes. If you do not see what you need within this list of standard parts, our engineers can custom design a muffler that meet your vessel's exact specifications.

VERNATONE® VERNASKI

Part #	A		C		D		Degrees	G
	Inlet/Outlet		Length		Diameter			
	IN	MM	IN	MM	IN	MM		
1000216	3.00	76	43.04	1093	4.34	110	0°	2
1000217	3.00	76	39.50	1003	4.34	110	45°	1
1000262	3.50	89	42.04	1068	4.34	110	0°	2
1000265	4.00	102	44.28	1125	4.30	109	0°	2
1000267	4.00	102	40.00	1016	4.00	102	45°	1

Parts listed are standard black; for custom color and/or finishes, please contact us.

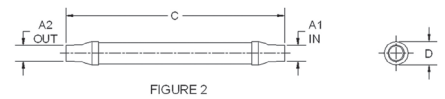
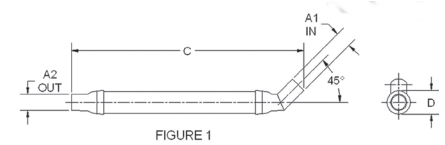

VERNATONE® MINIMAX

Part #	A				B				C		D	
	Inlet		Outlet		Inlet Length		Outlet Length		Length		Diameter	
	IN	MM	IN	MM	IN	MM	IN	MM	IN	MM	IN	MM
1050300	3.00	76	3.00	76	2.50	64	2.50	64	13.75	349	6.38	162
1050350	3.50	89	3.50	89	2.50	64	2.50	64	14.75	375	6.38	162
1059008	3.50	89	4.00	102	3.00	76	3.00	76	16.75	425	8.38	213
1050400	4.00	102	4.00	102	3.00	76	3.00	76	16.75	425	8.38	213
1050500	5.00	127	5.00	127	3.50	89	3.50	89	20.75	527	8.38	213
1059006	5.00	127	8.00	203	5.00	127	4.00	102	27.00	686	12.31	313
1050600	6.00	152	6.00	152	4.00	102	4.00	102	25.00	635	10.06	256
1059002	8.00	203	6.00	152	5.00	127	4.00	102	27.00	686	12.31	313

Parts listed are standard black; for custom color and/or finishes, please contact us.

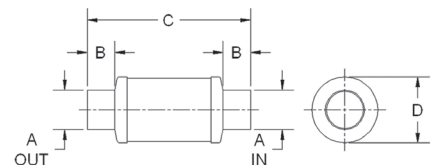

MARLIN MUFFLER

Part #	A		B		C		D	
	Inlet/Outlet		I/O Length		Length		Diameter	
	IN	MM	IN	MM	IN	MM	IN	MM
1090005	5.00	127	5.00	127	45.50	1156	8.38	213
1090006	6.00	152	6.00	152	49.50	1257	8.38	213
1090008	8.00	203	8.00	203	65.50	1664	10.06	256
1090010	10.00	254	10.00	254	80.75	2051	12.31	313
1090012	12.00	305	12.00	305	97.50	2477	14.38	365
1090014	14.00	356	12.00	305	109.50	2781	16.13	410
1090016	16.00	406	14.00	356	126.00	3200	18.38	467
1090018	18.00	457	16.00	406	142.00	3607	22.25	565



Parts listed are standard white gelcoat; for custom color and/or finishes, please contact us.

VERNATONE® OVAL VERTICAL MOUNT

Part #	A				B		C		H		J	
	Inlet		Outlet		I/O Length		Length		Height		Width	
	IN	MM	IN	MM	IN	MM	IN	MM	IN	MM	IN	MM
1000122	8.00	203	8.00	203	6.00	152	39.00	991	19.00	483	12.00	305
1000304	8.00	203	10.00	254	6.81	173	54.00	1372	19.19	487	11.81	300
1000170	10.00	254	10.00	254	7.44	189	39.00	991	19.13	486	12.00	305
1000253	10.53	267	10.53	267	8.35	212	65.50	1664	24.50	622	14.50	368

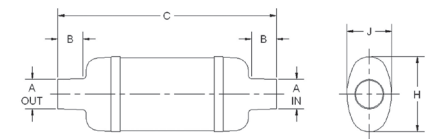

Parts listed are standard black; for custom color and/or finishes, please contact us.

VERNATONE® OVAL HORIZONTAL MOUNT

Part #	A		B		C		H		J	
	Inlet/Outlet		I/O Length		Length		Height		Width	
	IN	MM	IN	MM	IN	MM	IN	MM	IN	MM
1000229	5.00	127	5.00	127	35.13	892	7.00	178	14.63	372
1000263	6.00	152	6.00	152	33.00	838	9.00	229	15.06	383
1000194	10.00	254	7.56	192	65.50	1664	14.50	368	24.50	622

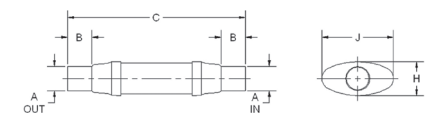

Parts listed are standard black; for custom color and/or finishes, please contact us.

VERNATONE® OVAL HORIZONTAL MOUNT (PORT & STARBOARD)

Part #	Port/ Starboard	A		B		C		H	
		Inlet/Outlet		I/O Length		Length		Height	
		IN	MM	IN	MM	IN	MM	IN	MM
1000149	Port	6.00	152	4.50	114	52.50	1334	3.19	81
1000150	Starboard	6.00	152	4.50	114	52.50	1334	3.19	81
1000162	Port	6.00	152	4.50	114	42.50	1080	3.31	84
1000163	Starboard	6.00	152	4.50	114	42.50	1080	3.31	84
1000140	Port	8.00	203	6.00	152	54.50	1384	3.19	81
1000141	Starboard	8.00	203	6.00	152	54.50	1384	3.19	81

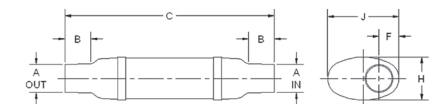

Parts listed are standard black; for custom color and/or finishes, please contact us.

VERNATONE® MKII ROUND

Part #	A1		A2		B		B		C		D		F	
	Inlet		Outlet		Inlet Length		Outlet Length		Length		Diameter		Outlet Offset	
	IN	MM	IN	MM	IN	MM	IN	MM	IN	MM	IN	MM	IN	MM
1400015	3.00	76	3.00	76	3.00	76	3.00	76	19.00	483	8.38	213	2.38	60
1400016	3.50	89	3.50	89	4.00	102	4.00	102	23.00	584	8.38	213	2.13	54
1400017	4.00	102	4.00	102	4.00	102	4.00	102	15.38	391	10.06	256	2.69	68
1400018	4.50	114	4.50	114	4.50	114	4.50	114	28.50	724	10.04	255	2.41	61
1400006	5.00	127	5.00	127	5.00	127	5.00	127	31.50	800	10.06	256	2.31	59
1400007	6.00	152	6.00	152	6.00	152	6.00	152	26.00	660	12.31	313	2.69	68
1400039	6.00	152	8.00	203	8.00	203	8.00	203	50.50	1283	16.13	410	3.56	90
1400008	8.00	203	8.00	203	8.00	203	8.00	203	50.50	1283	16.13	410	3.75	95
1400030	8.00	203	10.00	254	8.00	203	10.00	254	61.00	1549	18.44	468	3.81	97
1400009	10.00	254	10.00	254	10.00	254	10.00	254	63.00	1600	18.41	468	3.79	96
1400010	10.00	254	10.00	254	10.00	254	10.00	254	63.00	1600	18.41	468	3.79	96
1400011	14.00	356	14.00	356	12.00	305	12.00	305	87.10	2212	22.00	559	3.25	83

Parts listed are standard black; for custom color and/or finishes, please contact us.

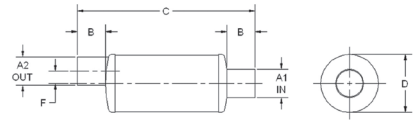

VERNATONE® MKII DUAL STAGE ROUND

Part #	A1		A2		B		C		D		F	
	Inlet		Outlet		I/O Length		Length		Diameter		I/O Offset	
	IN	MM	IN	MM	IN	MM	IN	MM	IN	MM	IN	MM
1420350	3.50	89	3.50	89	3.50	89	30.00	762	8.38	213	1.88	48
1420400	4.00	102	4.00	102	4.00	102	38.38	975	10.06	256	2.50	64
1420500	5.00	127	5.00	127	5.00	127	46.00	1168	10.06	256	1.75	44
1420600	6.00	152	6.00	152	6.00	152	54.00	1372	12.31	313	2.63	67
1420800	8.00	203	8.00	203	8.00	203	66.00	1676	16.13	410	3.50	89
1421000	10.00	254	10.00	254	8.00	203	81.00	2057	18.44	468	3.63	92
1421400	14.00	356	14.00	356	10.00	254	113.00	2870	22.00	559	3.50	89

Parts listed are standard black; for custom color and/or finishes, please contact us.

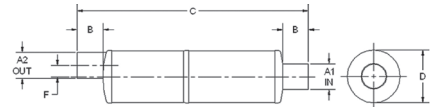

VERNATONE® MKII DUAL STAGE VERTICAL OVAL

Part #	A1/A2		B		C		H		J		F	
	Inlet/Outlet		I/O Length		Length		Height		Length		Outlet Offset	
	IN	MM	IN	MM	IN	MM	IN	MM	IN	MM	IN	MM
1429009	10.00	254	8.00	203	72.81	1849	18.50	470	14.50	368	3.63	92
1429010	8.00	203	8.00	203	70.50	1791	19.00	483	12.00	305	4.94	125

Parts listed are standard black; for custom color and/or finishes, please contact us.

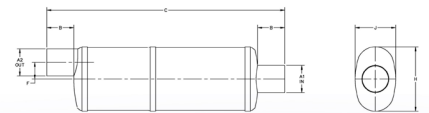

VERNATONE® MKII VERTICAL OVAL MOUNT

Part #	A1		A2		B		B		C		H		J		F	
	Inlet		Outlet		Inlet Length		Outlet Length		Length		Height		Width		Outlet Offset	
	IN	MM	IN	MM	IN	MM	IN	MM	IN	MM	IN	MM	IN	MM	IN	MM
1400042	5.00	127	5.00	127	5.56	141	5.56	141	31.50	800	14.50	368	8.50	216	4.56	116
1400043	6.00	152	6.00	152	6.00	152	6.00	152	32.38	822	14.50	368	8.50	216	4.06	103
1400004	6.00	152	8.00	203	6.00	152	6.00	152	53.38	1356	19.19	487	11.81	300	0.00	0
1400031	8.00	203	8.00	203	8.00	203	8.00	203	40.00	1016	16.50	419	10.50	267	3.69	94
1400044	8.00	203	8.00	203	8.00	203	8.00	203	50.50	1283	19.00	483	12.00	305	5.06	129
1400062	8.00	203	10.00	254	9.00	229	10.00	254	62.00	1575	24.50	622	14.50	368	6.63	168
1400045	10.00	254	10.00	254	10.00	254	10.00	254	63.00	1600	24.50	622	14.50	368	6.88	175
1400046	12.00	305	12.00	305	12.00	305	12.00	305	75.50	1918	29.75	756	17.75	451	8.13	207
1400028	14.00	356	14.00	356	12.00	305	12.00	305	77.00	1956	30.00	762	18.00	457	7.25	184

Parts listed are standard black; for custom color and/or finishes, please contact us.

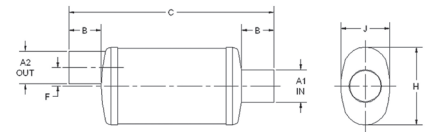

VERNATONE® ROUND

Part #	A		B		C		D	
	Inlet/Outlet		I/O Length		Length		Diameter	
	IN	MM	IN	MM	IN	MM	IN	MM
1000103	2.50	64	3.00	76	21.62	549	5.58	142
1000104	3.00	76	3.50	89	25.88	657	7.07	180
1000145	3.00	76	3.81	97	20.13	511	7.06	179
1000105	3.50	89	3.50	89	30.00	762	8.09	205
1000165	4.00	102	3.81	97	25.50	648	9.06	230
1000108	5.00	127	4.50	114	38.75	984	11.00	279
1000111	6.00	152	5.00	127	41.50	1054	12.20	310
1000113	6.00	152	6.00	152	52.75	1340	16.19	411
1000117	6.00	152	5.81	148	39.63	1007	16.19	411
1000112	6.00	152	5.00	127	31.43	798	12.20	310
1000119	8.00	203	6.00	152	52.75	1340	16.13	410
1000120	8.00	203	6.00	152	39.63	1007	16.13	410

Parts listed are standard black; for custom color and/or finishes, please contact us.

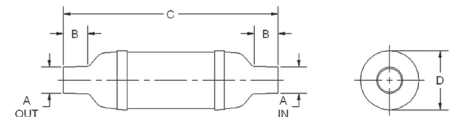

VERNATONE® ROUND PORT & STARBOARD

Part #	Type	A		B		C		D		F	
		Inlet/Outlet		I/O Length		Length		Diameter		I/O Offset	
		IN	MM	IN	MM	IN	MM	IN	MM	IN	MM
1000241	Port	4.00	102	4.00	102	27.00	686	8.00	203	2.38	60
1000242	Starboard	4.00	102	4.00	102	27.00	686	8.00	203	2.38	60
1000249	Port	5.00	127	4.75	121	35.63	905	10.00	254	3.08	78
1000250	Starboard	5.00	127	4.75	121	35.63	905	10.00	254	3.08	78

Parts listed are standard black; for custom color and/or finishes, please contact us.

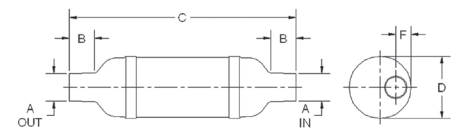



Vernalift®

In the 1970s, the quieting capabilities of the lift mufflers were recognized, and Centek Marine pioneered this design. Mufflers in this category are best suited for exhaust systems that require engine gases to be "lifted" above the waterline to be drained. Today, the Vernalift® line of products has expanded to include new and larger engines. It is the industry's best lift muffler and meets or exceeds the requirements of the ABYC P-1 Standards. Custom sizes and inlet/outlet configurations are available on all products.

VERNALIFT® INLINE

Part #	A1		A2		B				C		D		E	
	Inlet		Outlet		Inlet Length		Outlet Length		Length		Diameter		I/O Height	
	IN	MM	IN	MM	IN	MM	IN	MM	IN	MM	IN	MM	IN	MM
1500035	1.50	38	1.50	38	2.00	51	2.00	51	10.50	267	6.38	162	4.89	124
1500042	2.00	51	2.00	51	2.00	51	2.00	51	10.50	267	6.38	162	4.89	124
1500043	2.00	51	2.00	51	2.00	51	2.00	51	14.00	356	8.38	213	6.19	157
1500044	2.00	51	2.00	51	2.00	51	2.00	51	17.50	445	10.04	255	7.52	191
1500051	3.00	76	3.00	76	3.00	76	3.00	76	17.50	445	10.04	255	7.52	191
1500098	4.00	102	4.00	102	4.00	102	4.00	102	22.00	559	12.34	313	9.17	233
1500100	5.00	127	5.00	127	5.00	127	5.00	127	22.00	559	12.34	313	9.17	233
1500101	6.00	152	6.00	152	6.00	152	6.00	152	28.00	711	16.17	411	12.47	317
1500102	8.00	203	8.00	203	6.00	152	6.00	152	32.00	813	18.44	468	13.72	348
1500169	10.00	254	10.00	254	8.00	203	8.00	203	40.00	1016	22.00	559	16.00	406

Parts listed are standard black; for custom color and/or finishes, please contact us.

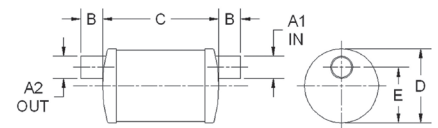

VERNALIFT® SIDE ANGLE IN/TOP OUT

Part #	A1/A2		B1		B2		D		E		F		H		N	S	
	Inlet/Outlet		Inlet Length		Outlet Length		Diameter		Inlet Height		Outlet Offset		Height		Angle	Sq Base	
	IN	MM	IN	MM	IN	MM	IN	MM	IN	MM	IN	MM	IN	MM	Degree	IN	MM
1500107	2.00	51	3.00	76	1.88	48	10.06	256	5.13	130	2.50	64	10.19	259	45°	10.50	267
1500171	2.00	51	2.50	64	2.00	51	8.38	213	6.19	157	2.00	51	8.00	203	45°	9.00	229
1500268	2.00	51	2.50	64	2.00	51	6.38	162	4.50	114	1.50	38	9.00	229	45°	7.00	178
1500112	3.00	76	3.00	76	3.00	76	12.31	313	6.50	165	2.75	70	12.00	305	45°	13.00	330
1500113	3.50	89	3.38	86	4.00	102	12.31	313	7.25	184	2.75	70	12.00	305	30°	13.00	330
1500114	4.00	102	4.00	102	4.00	102	12.31	313	6.75	171	2.75	70	12.00	305	30°	13.00	330
1500198	4.00	102	5.69	145	4.00	102	12.31	313	5.69	145	2.75	70	12.00	305	45°	13.00	330
1500116	5.00	127	5.00	127	5.00	127	12.31	313	5.88	149	2.75	70	12.00	305	30°	13.00	330
1500117	6.00	152	6.00	152	5.00	127	16.13	410	8.50	216	4.00	102	14.50	368	45°	17.00	432
1500118	8.00	203	9.31	236	6.00	152	18.44	468	9.75	248	3.00	76	18.00	457	45°	19.00	483

Parts listed are standard black; for custom color and/or finishes, please contact us.

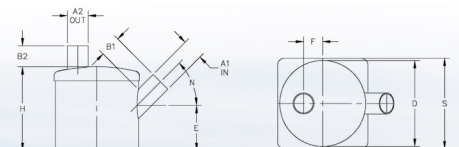

VERNALIFT® SIDE IN/TOP OUT

Part #	A1		A2		B1		B2		D		E		F		H		S	
	Inlet		Outlet		Inlet Length		Outlet Length		Diameter		Inlet Height		Outlet Offset		Height		Sq Base	
	IN	MM	IN	MM	IN	MM	IN	MM	IN	MM	IN	MM	IN	MM	IN	MM	IN	MM
1500225	1.50	38	1.50	38	2.50	64	2.00	51	12.34	313	8.09	205	2.75	70	12.00	305	13.00	330
1500275	1.50	38	1.50	38	2.00	51	2.50	64	6.38	162	5.81	148	1.50	38	9.00	229	7.00	178
1500142	1.50	38	2.00	51	2.50	64	2.00	51	8.38	213	4.50	114	2.00	51	8.00	203	9.00	229
1500222	1.63	41	1.50	38	2.50	64	2.50	64	8.44	214	4.50	114	2.00	51	8.00	203	9.00	229
1500239	1.63	41	1.63	41	2.50	64	2.00	51	12.31	313	7.69	195	2.75	70	12.00	305	13.00	330
1500262	1.63	41	1.63	41	2.00	51	2.00	51	6.38	162	5.19	132	1.50	38	9.00	229	7.00	178
1500140	1.63	41	1.75	44	2.50	64	2.00	51	8.38	213	4.69	119	2.00	51	8.00	203	9.00	229
1500162	1.75	44	1.75	44	2.00	51	2.00	51	10.06	256	6.31	160	2.50	64	10.00	254	10.50	267
1500206	1.75	44	1.75	44	2.50	64	2.00	51	12.31	313	7.81	198	2.75	70	12.00	305	13.00	330
1500148	1.75	44	2.00	51	2.50	64	2.00	51	10.06	256	6.31	160	2.50	64	10.00	254	10.50	267
1500146	1.88	48	1.63	41	2.50	64	2.50	64	10.06	256	6.31	160	2.50	64	10.19	259	10.50	267
1500263	1.88	48	1.88	48	2.00	51	2.00	51	6.38	162	5.81	148	1.50	38	9.00	229	7.00	178
1500075	1.88	48	2.00	51	2.50	64	2.00	51	8.44	214	4.50	114	2.00	51	8.00	203	9.00	229
1500210	2.00	51	1.50	38	2.50	64	2.00	51	8.38	213	4.69	119	2.00	51	8.00	203	9.00	229
1500292	2.00	51	1.50	38	2.50	64	2.50	64	6.38	162	5.81	148	1.50	38	9.00	229	7.00	178
1500337	2.00	51	1.63	41	2.50	64	2.50	64	6.38	162	5.81	148	1.50	38	9.00	229	7.00	178
1500264	2.00	51	2.00	51	2.00	51	2.00	51	6.38	162	5.81	148	1.50	38	9.00	229	7.00	178
1500123	2.00	51	2.00	51	2.38	60	2.00	51	6.69	170	5.81	148	1.63	41	9.19	233	7.25	184
1500147	2.00	51	2.25	57	2.00	51	3.00	76	12.31	313	8.06	205	2.50	64	12.00	305	13.00	330
1500137	2.00	51	2.50	64	2.50	64	2.00	51	8.38	213	4.50	114	2.00	51	8.00	203	9.00	229
1500256	2.00	51	3.00	76	3.00	76	2.50	64	10.06	256	5.56	141	2.50	64	10.00	254	10.50	267
1500308	2.25	57	2.25	57	2.50	64	2.00	51	12.31	313	8.06	205	2.50	64	12.00	305	13.00	330
1500297	2.50	64	3.00	76	2.50	64	3.00	76	10.06	256	6.31	160	2.50	64	10.19	259	10.50	267
1500289	3.00	76	1.88	48	2.00	51	2.00	51	6.38	162	5.81	148	1.50	38	9.00	229	7.00	178
1500217	3.00	76	2.50	64	3.00	76	3.00	76	12.31	313	7.56	192	2.75	70	12.00	305	13.00	330
1500226	3.00	76	2.50	64	3.00	76	2.50	64	10.06	256	6.31	160	2.25	57	10.00	254	10.50	267
1500341	3.00	76	2.50	64	3.00	76	2.50	64	10.06	256	2.50	64	2.50	64	10.00	254	10.50	267
1500232	3.00	76	3.00	76	3.00	76	2.50	64	10.06	256	4.56	116	2.25	57	10.00	254	10.50	267
1500235	3.00	76	3.00	76	3.00	76	3.00	76	12.31	313	4.38	111	2.75	70	12.00	305	13.00	330
1500152	3.00	76	3.50	89	3.50	89	3.50	89	10.06	256	6.38	162	2.50	64	10.00	254	10.50	267
1500197	3.00	76	3.50	89	3.00	76	3.00	76	12.34	313	8.09	205	2.50	64	12.00	305	13.00	330
1500182	3.00	76	4.00	102	3.00	76	4.00	102	12.31	313	7.38	187	2.75	70	12.00	305	13.00	330
1500135	3.50	89	3.50	89	3.50	89	3.50	89	10.04	255	6.31	160	0.00	0	10.81	275	10.50	267
1500174	3.50	89	4.00	102	4.00	102	4.00	102	12.34	313	7.59	193	2.75	70	12.00	305	13.00	330
1500151	3.50	89	5.00	127	3.50	89	5.00	127	12.34	313	7.35	187	2.75	70	12.00	305	13.00	330
1500280	4.00	102	4.00	102	4.00	102	5.00	127	16.13	410	8.75	222	4.00	102	16.00	406	17.00	432
1500319	4.00	102	4.00	102	4.00	102	4.00	102	10.06	256	5.81	148	2.50	64	10.00	254	10.50	267
1500229	4.00	102	4.50	114	4.00	102	4.50	114	12.31	313	6.88	175	2.75	70	12.00	305	13.00	330
1500149	4.00	102	5.00	127	5.00	127	5.00	127	18.25	464	8.50	216	4.00	102	16.00	406	17.00	432
1500227	4.00	102	5.00	127	4.00	102	4.00	102	12.31	313	7.38	187	2.75	70	12.00	305	13.00	330
1500144	5.00	127	6.00	152	5.00	127	5.00	127	12.31	313	6.88	175	2.25	57	12.00	305	13.00	330
1500183	5.00	127	6.00	152	5.00	127	6.00	152	14.38	365	7.25	184	3.00	76	14.00	356	15.00	381
1500186	5.00	127	6.00	152	5.00	127	6.00	152	16.11	409	8.50	216	4.00	102	16.00	406	17.00	432
1500326	6.00	152	6.00	152	6.00	152	5.00	127	12.31	313	6.06	154	2.25	57	12.00	305	13.00	330
1500184	6.00	152	8.00	203	6.00	152	6.00	152	18.44	468	18.00	457	3.00	76	18.00	457	19.00	483
1500205	8.00	203	10.00	254	8.00	203	8.00	203	26.00	660	11.75	298	6.00	152	22.44	570	26.00	660
1500204	8.50	216	8.50	216	6.00	152	6.00	152	18.44	468	15.25	387	3.00	76	23.00	584	19.00	483
1500331	8.50	216	8.50	216	6.00	152	6.00	152	18.44	468	10.25	260	3.00	76	18.00	457	19.00	483
1500159	10.00	254	10.00	254	8.00	203	8.00	203	24.63	626	11.75	298	6.00	152	24.00	610	26.00	660
1500254	12.00	305	12.00	305	10.00	254	10.00	254	28.46	723	17.50	445	7.75	197	28.00	711	30.00	762
1500255	14.00	356	14.00	356	10.00	254	10.00	254	28.46	723	16.19	411	6.75	171	28.00	711	30.00	762

Parts listed are standard black; for custom color and/or finishes, please contact us.

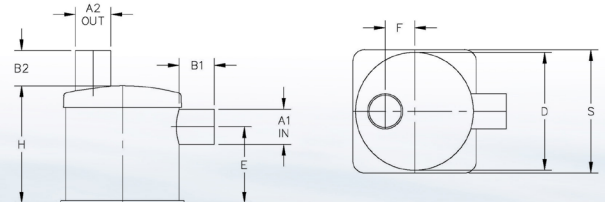

VERNALIFT® TOP IN/TOP OUT

Part #	A1		A2		B		D		F		H		S	
	Inlet		Outlet		I/O Length		Diameter		I/O Offset		Height		Sq Base	
	IN	MM	IN	MM	IN	MM	IN	MM	IN	MM	IN	MM	IN	MM
1500001	1.50	38	1.50	38	2.00	51	6.36	162	1.50	38	6.14	156	7.00	178
1500060	1.50	38	1.50	38	2.50	64	8.38	213	2.00	51	8.00	203	9.00	229
1500270	1.63	41	1.63	41	2.00	51	6.38	162	1.50	38	9.00	229	7.00	178
1500143	1.63	41	1.88	48	2.50	64	8.38	213	2.00	51	8.00	203	9.00	229
1500003	1.63	41	1.63	41	2.50	64	8.38	213	2.00	51	10.50	267	9.00	229
1500201	1.75	44	1.88	48	2.00	51	6.36	162	1.50	38	6.19	157	7.00	178
1500329	1.88	48	1.88	48	2.00	51	6.36	162	1.50	38	9.00	229	7.00	178
1500302	2.00	51	2.00	51	2.00	51	6.36	162	1.50	38	12.00	305	7.00	178
1500126	2.00	51	2.38	60	2.50	64	8.38	213	2.00	51	8.00	203	9.00	229
1500010	2.00	51	2.00	51	2.50	64	10.06	256	2.50	64	10.19	259	10.50	267
1500011	2.25	57	2.25	57	2.50	64	8.38	213	2.00	51	10.50	267	9.00	229
1500013	2.38	60	2.38	60	2.50	64	8.38	213	2.00	51	10.50	267	9.00	229
1500303	2.38	60	2.38	60	3.00	76	12.31	313	2.75	70	12.00	305	13.00	330
1500015	2.50	64	2.50	64	2.50	64	10.50	267	2.50	64	10.19	259	10.50	267
1500141	2.50	64	2.50	64	3.00	76	12.31	313	2.75	70	12.00	305	13.00	330
1500016	2.88	73	2.88	73	3.00	76	10.06	256	2.50	64	13.19	335	10.50	267
1500017	3.00	76	3.00	76	3.00	76	10.06	256	2.50	64	10.19	259	10.50	267
1500150	3.00	76	3.50	89	4.00	102	12.31	313	2.75	70	12.00	305	13.00	330
1500063	3.00	76	3.00	76	4.00	102	12.31	313	2.75	70	12.00	305	13.00	330
1500064	3.50	89	3.50	89	4.00	102	12.31	313	2.75	70	12.00	305	13.00	330
1500065	4.00	102	4.00	102	4.00	102	12.31	313	2.75	70	12.00	305	13.00	330
1500306	4.00	102	4.50	114	4.00	102	16.11	409	4.00	102	16.00	406	17.00	432
1500298	4.00	102	5.00	127	5.00	127	14.36	365	3.50	89	14.00	356	15.00	381
1500066	4.50	114	4.50	114	4.00	102	12.34	313	3.00	76	12.00	305	13.00	330
1500271	5.00	127	5.00	127	5.00	127	12.31	313	3.31	84	12.00	305	13.00	330
1500069	6.00	152	6.00	152	5.00	127	16.13	410	4.00	102	14.25	362	17.00	432
1500339	6.00	152	8.00	203	6.00	152	18.44	468	5.00	127	18.00	457	19.00	483
1500154	10.00	254	10.00	254	8.00	203	28.44	722	7.00	178	28.00	711	30.00	762
1500315	12.00	305	12.00	305	10.00	254	34.75	883	9.00	229	34.00	864	36.00	914

Parts listed are standard black; for custom color and/or finishes, please contact us.

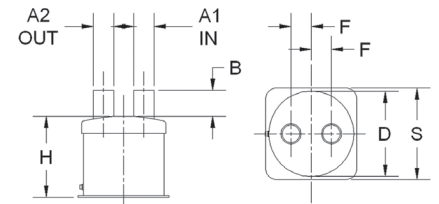

VERNALIFT® DUAL STAGE SIDE IN/TOP OUT

Part #	A1		B		D		E		F		H		S	
	Inlet/Outlet		I/O Length		Diameter		Inlet Height		Outlet Offset		Height		Sq Base	
	IN	MM	IN	MM	IN	MM	IN	MM	IN	MM	IN	MM	IN	MM
1529001	2.00	51	2.00	51	8.38	213	3.94	100	1.75	44	12.00	305	9.00	229
1529007	3.00	76	3.00	76	10.04	255	4.75	121	2.50	64	14.25	362	10.50	267
1529003	4.00	102	4.00	102	12.31	313	5.00	127	3.25	83	16.25	413	13.00	330

Parts listed are standard black; for custom color and/or finishes, please contact us.

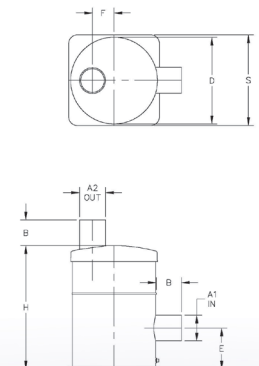

VERNALIFT® DUAL STAGE

Part #	A1		B		D		E1		E2		H		S	
	Inlet/Outlet		I/O Length		Diameter		Inlet Height		Outlet Height		Height		Sq Base	
	IN	MM	IN	MM	IN	MM	IN	MM	IN	MM	IN	MM	IN	MM
1520200	2.00	51	2.50	64	8.38	213	4.00	102	8.00	203	11.25	286	9.00	229
1520300	3.00	76	3.00	76	10.06	256	4.75	121	10.25	260	14.25	362	10.50	267
1520400	4.00	102	4.00	102	12.31	313	5.00	127	11.50	292	16.25	413	13.00	330
1520500	5.00	127	5.00	127	12.31	313	5.75	146	13.75	349	19.00	483	13.00	330
1520600	6.00	152	6.00	152	16.13	410	7.00	178	16.25	413	22.50	572	17.00	432
1520800	8.00	203	8.00	203	18.44	468	9.00	229	21.00	533	29.25	743	19.00	483
1521000	10.00	254	8.00	203	22.00	559	12.00	305	26.25	667	36.00	914	23.00	584
1521200	12.00	305	10.00	254	24.60	625	13.00	330	30.00	762	41.00	1041	26.50	673
1521400	14.00	356	10.00	254	28.46	723	16.00	406	34.50	876	46.00	1168	30.00	762

Parts listed are standard black; for custom color and/or finishes, please contact us.

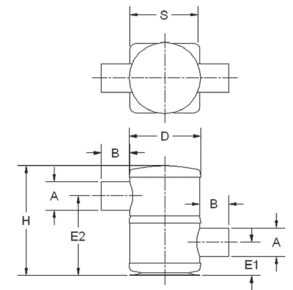

VERNALIFT® COMPACT-TOP IN / TOP OUT

Part #	A		B		C		F		H		J	
	Inlet/Outlet		I/O Length		Length		I/O Offset		Height		Width	
	IN	MM	IN	MM	IN	MM	IN	MM	IN	MM	IN	MM
15C1150	1.50	38	1.50	38	12.00	305	2.75	70	6.56	167	7.00	178
15C1163	1.63	41	1.63	41	12.00	305	2.75	70	6.56	167	7.00	178
15C1175	1.75	44	1.75	44	12.00	305	2.75	70	6.56	167	7.00	178
15C1200	2.00	51	2.00	51	12.00	305	2.75	70	6.56	167	7.00	178

Parts listed are standard black; for custom color and/or finishes, please contact us.

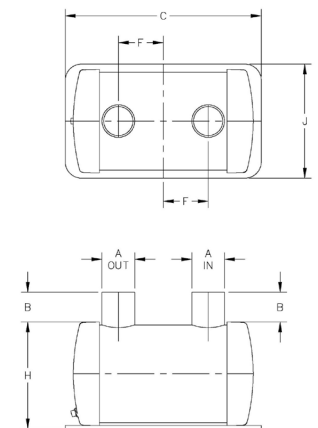

VERNALIFT® COMPACT-SIDE IN / TOP OUT

Part #	A		B		C		F		H		J	
	Inlet/Outlet		I/O Length		Length		I/O Offset		Height		Width	
	IN	MM	IN	MM	IN	MM	IN	MM	IN	MM	IN	MM
15C2150	1.50	38	1.50	38	12.00	305	2.75	70	6.56	167	7.00	178
15C2152	1.63	41	1.63	41	12.00	305	2.75	70	6.56	167	7.00	178
15C2188	1.75	44	1.75	44	12.00	305	2.75	70	6.56	167	7.00	178
15C2200	2.00	51	2.00	51	12.00	305	2.75	70	6.56	167	7.00	178

Parts listed are standard black; for custom color and/or finishes, please contact us.

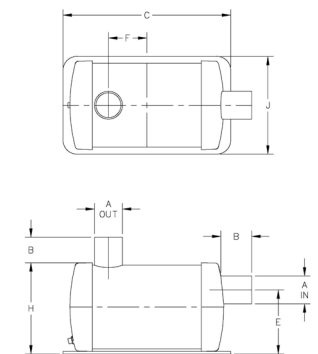



Gas/Water Separation Mufflers

The routing of exhaust gases and cooling water in some complex vessels brought about the development of new types of muffler products. Centek Marine has met these needs with its gas/water separation mufflers. Separation systems are very effective where engines are located midship or well forward in the hull and extremely effective in reducing exhaust noise.

GEN-SEP®

Part #	A1		A1		A2		H		J		K	
	Inlet		Outlet		Drain		Height		Width		Depth	
	IN	MM	IN	MM	IN	MM	IN	MM	IN	MM	IN	MM
1020150	1.50	38	1.50	38	1.25	32	15.63	397	12.38	314	5.38	137
1029037	1.50	38	1.50	38	1.25	32	15.63	397	12.38	314	5.38	137
1020200	2.00	51	2.00	51	1.50	38	15.63	397	12.38	314	5.38	137
1029003	2.00	51	2.00	51	1.50	38	15.63	397	12.38	314	5.38	137
1029005	2.00	51	2.00	51	1.50	38	15.63	397	12.38	314	5.38	137
1029023	2.00	51	2.00	51	1.50	38	15.63	397	12.38	314	5.38	137
1020250	2.50	64	2.50	64	1.50	38	18.00	457	17.50	445	7.19	183
1029029	2.50	64	2.50	64	1.50	38	21.00	533	18.00	457	7.63	194
1029041	2.50	64	2.50	64	1.50	38	20.50	521	17.50	445	7.00	178
1029020	3.00	76	2.00	51	2.00	51	20.50	521	17.50	445	7.19	183
1029021	3.00	76	2.00	51	2.00	51	20.50	521	17.50	445	7.19	183
1020300	3.00	76	3.00	76	1.50	38	20.50	521	17.50	445	7.19	183
1020301	3.00	76	3.00	76	1.50	38	15.63	397	12.38	314	5.25	133
1029008	3.00	76	3.00	76	1.50	38	21.00	533	18.00	457	7.31	186
1029009	3.00	76	3.00	76	1.50	38	21.00	533	18.00	457	7.31	186
1020350	3.50	89	3.50	89	2.00	51	27.00	686	23.50	597	9.19	233
1020351	3.50	89	3.50	89	2.00	51	21.00	533	18.00	457	7.56	192
1029050	3.50	89	3.50	89	2.00	51	27.00	686	23.50	597	9.19	233
1029053	3.50	89	3.50	89	2.00	51	21.00	533	18.00	457	7.56	192
1029054	3.50	89	3.50	89	2.00	51	21.00	533	18.00	457	7.56	192
1023550	3.50	89	5.00	127	3.00	76	27.00	686	23.50	597	9.19	233
1020400	4.00	102	4.00	102	2.50	64	27.00	686	23.50	597	9.19	233
1020450	4.00	102	4.00	102	2.50	64	27.00	686	23.50	597	9.19	233
1029001	4.00	102	4.00	102	2.50	64	27.00	686	23.50	597	9.19	233
1029002	4.00	102	4.00	102	2.50	64	27.00	686	23.50	597	9.19	233
1029055	5.00	127	4.00	102	3.00	76	30.00	762	28.00	711	7.25	184
1029056	5.00	127	4.00	102	3.00	76	27.00	686	23.50	597	9.19	233
1020500	5.00	127	5.00	127	3.00	76	27.00	686	23.50	597	9.19	233
1029042	5.00	127	5.00	127	3.00	76	27.00	686	23.50	597	9.19	233
1029043	5.00	127	5.00	127	3.00	76	27.00	686	23.50	597	9.19	233

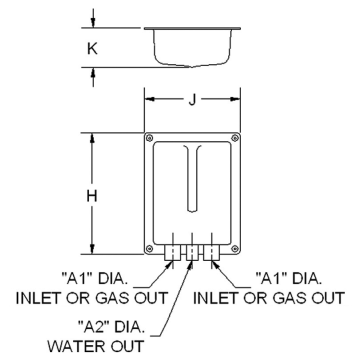

Parts listed are standard white; for custom color and/or finishes, please contact us.

Combo-Sep®

The patented Combo-Sep® combines a Vernalift® muffler and a highly efficient gas/water separator into a single space saving unit. The Combo-Sep® is excellent for mid-range generators and propulsion engines installed amidship or forward. Centek Marine recommends the Combo-Sep® for above waterline installations for maximum silencing and excellent water separation.



COMBO-SEP® HORIZONTAL

Part #	A1		A2		A3		B		C		F		H		J		M	
	Inlet		Gas Outlet		Water Outlet		I/O Length		Length		Offset		Height		Width		BP Offset	
	IN	MM	IN	MM	IN	MM	IN	MM	IN	MM	IN	MM	IN	MM	IN	MM	IN	MM
104H200	2.00	51	2.00	51	1.50	38	4.00	102	44.00	1118	2.00	51	14.63	372	6.94	176	4.00	102
104H300	3.00	76	3.00	76	2.00	51	5.00	127	49.00	1245	2.00	51	14.63	372	6.94	176	4.00	102
104H400	4.00	102	4.00	102	2.50	64	5.00	127	56.00	1422	1.50	38	15.38	391	9.38	238	3.69	94
104H402	4.00	102	4.00	102	2.50	64	5.00	127	56.00	1422	1.50	38	15.38	391	9.38	238	5.00	127
104H500	5.00	127	5.00	127	3.00	76	5.00	127	65.00	1651	3.00	76	19.00	483	12.00	305	5.00	127

Parts listed are standard white; for custom color and/or finishes, please contact us.

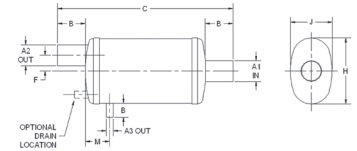

COMBO-SEP® VERTICAL

Part #	A1		A2		A3		D		E1		E2		E3		H		S	
	Inlet		Gas Outlet		Water Outlet		Diameter		Inlet		Gas Outlet		Water Outlet		Height		Square Base	
	IN	MM	IN	MM	IN	MM	IN	MM	IN	MM	IN	MM	IN	MM	IN	MM	IN	MM
1040200	2.00	51	1.50	38	1.25	32	10.06	256	3.75	95	16.50	419	8.13	206	20.00	508	10.50	267
1040300	3.00	76	2.50	64	1.50	38	10.06	256	3.75	95	16.50	419	8.13	207	20.00	508	10.50	267
1040350	3.50	89	3.00	76	2.00	51	12.31	313	5.00	127	19.50	495	10.44	265	26.00	660	13.00	330
1040400	4.00	102	3.00	76	2.50	64	12.31	313	5.00	127	21.00	533	10.69	272	26.00	660	13.00	330
1040500	5.00	127	4.00	102	2.50	64	14.38	365	6.00	152	25.00	635	12.38	314	30.00	762	15.00	381
1040600	6.00	152	5.00	127	3.00	76	16.13	410	7.00	178	29.25	743	14.25	362	35.00	889	17.00	432

Parts listed are standard black; for custom color and/or finishes, please contact us.

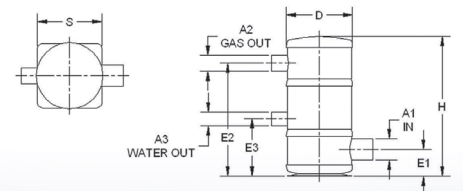



Underwater Exhaust

This exhaust silencer was designed specifically for use with underwater exhaust systems. It combines Centek Marine's experience in muffler design with all the benefits of an underwater discharge. Benefits include the elimination of the exhaust gases flowing back into the boat and the elimination of engine exhaust deposits (soot) staining the exterior surfaces of the boat. The underwater exhaust comes in a vertical or horizontal design, depending on your engine room's size and configuration.

UNDERWATER EXHAUST HORIZONTAL

Part #	A1		A2		B1		B2		C		D		E1		E2		M	
	Inlet/Outlet		Bypass		I/O Length		BP Length		Length		Diameter		I/O Elevation		BP Elevation		BP Offset	
	IN	MM	IN	MM	IN	MM	IN	MM	IN	MM	IN	MM	IN	MM	Degree	IN	MM	
107H500	5.00	127	2.50	64	5.00	127	3.00	76	34.00	864	10.40	264	2.16	55	2.75	70	13.82	351
107H600	6.00	152	3.00	76	6.00	152	4.88	124	34.00	864	12.31	313	2.81	71	2.81	71	17.00	432
107H800	8.00	203	4.00	102	8.00	203	4.00	102	45.00	1143	16.11	409	3.72	94	3.72	94	22.50	572
107H100	10.00	254	5.00	127	8.00	203	7.56	192	52.00	1321	18.44	468	3.80	97	3.81	97	26.00	660
107H120	12.00	305	6.00	152	8.00	203	6.00	152	60.00	1524	24.60	625	5.75	146	5.75	146	30.00	762
107H140	14.00	356	6.00	152	8.00	203	6.00	152	66.00	1676	28.50	724	6.75	171	6.75	171	33.00	838
107H160	16.00	406	8.00	203	10.00	254	8.00	203	78.00	1981	28.50	724	5.75	146	5.75	146	39.00	991
107H180	18.00	457	8.00	203	10.00	254	8.00	203	85.00	2159	34.00	864	7.75	197	7.75	197	42.50	1080

Parts listed are standard white; for custom color and/or finishes, please contact us.

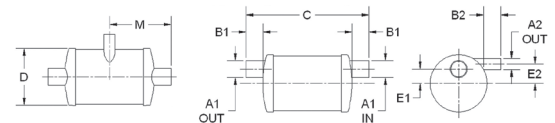

UNDERWATER EXHAUST VERTICAL

Part #	A1		A2		B1		B2		C		D		E1		E2		H	
	Inlet/Outlet		Bypass		I/O Length		BP Length		Length		Diameter		Inlet Elevation		BP Elevation		Height	
	IN	MM	IN	MM	IN	MM	IN	MM	IN	MM	IN	MM	IN	MM	Degree	IN	MM	
107V500	5.00	127	2.50	64	5.00	127	3.00	76	20.00	508	12.31	313	10.06	256	5.56	141	21.00	533
107V600	6.00	152	3.00	76	6.00	152	4.00	102	24.06	611	14.38	365	10.69	272	5.69	145	24.50	622
107V100	10.00	254	5.00	127	9.00	229	5.00	127	35.38	899	22.00	559	17.19	437	8.69	221	37.50	953
107V120	12.00	305	6.00	152	10.00	254	6.00	152	40.00	1016	24.60	625	21.89	556	11.89	302	44.50	1130
107V140	14.00	356	6.00	152	11.00	279	6.00	152	45.50	1156	28.50	724	38.75	984	6.75	171	50.50	1283
107V160	16.00	406	8.00	203	12.00	305	8.00	203	55.00	1397	35.00	889	45.63	1159	5.75	146	58.00	1473
107V180	18.00	457	8.00	203	13.00	330	8.00	203	55.00	1397	34.75	883	32.06	814	18.31	465	62.00	1575

Parts listed are standard white; for custom color and/or finishes, please contact us.

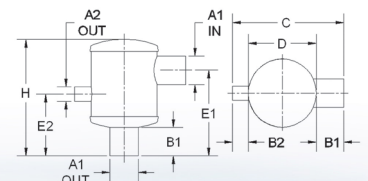

Tubing

Vernatube® is a resin-impregnated glass filament wound tubing made exclusively with a fire-retardant resin formulated for high temperature applications. Centek Marine uses the fire-retardant Vernatube to fabricate many of the basic marine exhaust components. Vernatube exceeds values for the class of materials designated as 'self-extinguishing' per ASTM-D-635, UL94V-O, and the US Navy/USCG MIL-R-21607 and MIL-R-7575.

The smooth, resin-rich I.D. assures minimal restriction to exhaust gases and cooling water flowing through the tubing. Precise control of the outside diameter ensures ease of connecting mating ports with marine exhaust hose. All tubing products may be factory machined to fit exact hull dimensions. Contact us to discuss machining options.

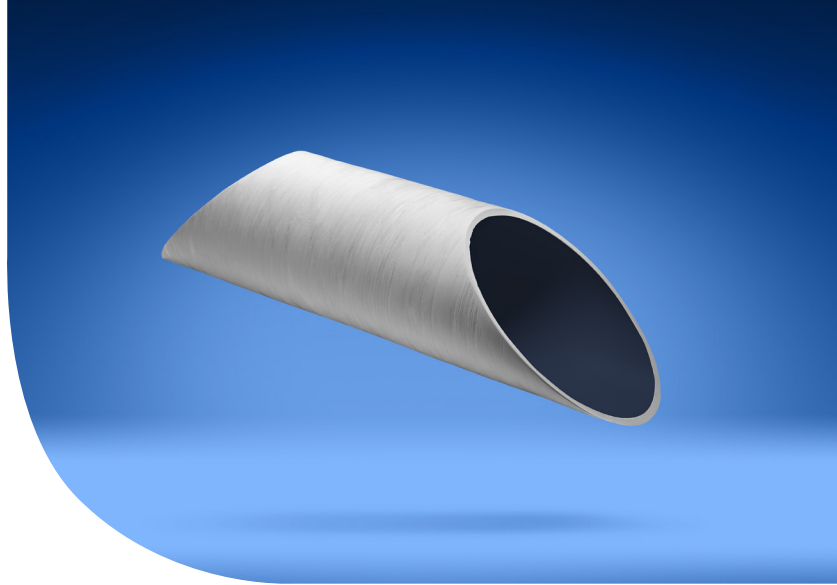

THRUSTER TUNNELS

Part #	I.D.		O..D.		Interior Finish	Exterior Finish	Standard			
							Length			
	IN	MM	IN	MM			IN	MM		
1100614	4.33	110	4.72	120	Natural	Natural	120.00	3048		
1100615	4.33	110	4.72	120	White Gel Coat	Natural	120.00	3048		
1100600	5.51	140	5.91	150	natural	natural	120.00	3048		
1100601	5.51	140	5.91	150	White Gel Coat	White Gel Coat	120.00	3048		
1100602	5.51	140	5.91	150	gel coat	pigment	120.00	3048		
1100603	7.28	185	7.72	196	Natural	Natural	120.00	3048		
1100604	7.28	185	7.72	196	White Gel Coat	Natural	120.00	3048		
1100605	7.28	185	7.72	196	White Gel Coat + Pigment	White Pigment	120.00	3048		
1100606	7.28	185	7.75	197	natural	Natural	120.00	3048		
1100607	7.28	185	7.75	197	White Gel Coat	Natural	120.00	3048		
1100608	7.28	185	7.75	197	White Gel Coat + Pigment	White Pigment	120.00	3048		
1100616	7.28	185	7.60	193	White Gel Coat + Pigment	White Pigment	120.00	3048		

Vernatube® - 0.63-3.5" Nominal O.D.								
Part #	Nominal		Nominal		Nominal		Standard	
	O.D.		I.D.		Wall		Length	
	IN	MM	IN	MM	IN	MM	IN	MM
1100528-5	0.63	16	0.43	11	0.1	3	60.00	1524
1100530-5	0.75	19	0.5	13	0.125	3	60.00	1524
1100525-1	1.00	25	0.77	20	0.115	3	12.00	305
1100525-3	1.00	25	0.77	20	0.115	3	36.00	914
1100525-5	1.00	25	0.77	20	0.115	3	60.00	1524
1100528-1	1.00	25	0.64	16	0.180	5	12.00	305
1100533-10	1.13	29	0.77	20	0.180	5	120.00	3048
1100526-10	1.25	32	0.98	25	0.135	3	120.00	3048
1100526-3	1.25	32	0.98	25	0.135	3	36.00	914
1100526-5	1.25	32	0.98	25	0.135	3	60.00	1524
1100521-1	1.50	38	1.29	33	0.105	3	12.00	305
1100521-10	1.50	38	1.29	33	0.105	3	120.00	3048
1100521-3	1.50	38	1.29	33	0.105	3	36.00	914
1100521-5	1.50	38	1.29	33	0.105	3	60.00	1524
1100522-1	1.63	41	1.40	36	0.115	3	12.00	305
1100522-10	1.63	41	1.40	36	0.115	3	120.00	3048
1100523-10	1.75	44	1.52	39	0.115	3	120.00	3048
1100523-5	1.75	44	1.52	39	0.115	3	60.00	1524
1100524-10	1.88	48	1.64	42	0.120	3	120.00	3048
1100524-5	1.88	48	1.64	42	0.120	3	60.00	1524
1100512-1	2.00	51	1.75	44	0.125	3	12.00	305
1100512-10	2.00	51	1.75	44	0.125	3	120.00	3048
1100512-3	2.00	51	1.75	44	0.125	3	36.00	914
1100512-5	2.00	51	1.75	44	0.125	3	60.00	1524
1100510-10	2.25	57	2.00	51	0.125	3	120.00	3048
1100511-10	2.38	60	2.11	54	0.135	3	120.00	3048
1100511-5	2.38	60	2.11	54	0.135	3	60.00	1524
1100501-10	2.50	64	2.25	57	0.125	3	120.00	3048
1100501-5	2.50	64	2.25	57	0.125	3	60.00	1524
1100502-10	3.00	76	2.74	70	0.130	3	120.00	3048
1100502-3	3.00	76	2.74	70	0.130	3	36.00	914
1100502-5	3.00	76	2.74	70	0.130	3	60.00	1524
1100527-1	3.25	83	3.00	76	0.125	3	12.00	305
1100527-10	3.25	83	3.00	76	0.125	3	120.00	3048
1100503-10	3.50	89	3.24	82	0.13	3	120.00	3048

Vernatube® - 4.00-18.00" Nominal O.D.								
Part #	Nominal		Nominal		Nominal		Standard	
	O.D.		I.D.		Wall		Length	
	IN	MM	IN	MM	IN	MM	IN	MM
1100504-10	4.00	102	3.73	95	0.135	3	120.00	3048
1100504-3	4.00	102	3.73	95	0.135	3	36.00	914
1100504-5	4.00	102	3.73	95	0.135	3	60.00	1524
1100505-10	4.50	114	4.22	107	0.140	4	120.00	3048
1100505-5	4.50	114	4.22	107	0.140	4	60.00	1524
1100506-1	5.00	127	4.71	120	0.145	4	12.00	305
1100506-10	5.00	127	4.71	120	0.145	4	120.00	3048
1100506-12	5.00	127	4.71	120	0.145	4	144.00	3658
1100506-3	5.00	127	4.71	120	0.145	4	36.00	914
1100506-5	5.00	127	4.71	120	0.145	4	60.00	1524
1100531-1	5.50	140	4.94	125	0.280	7	12.00	305
1100531-10	5.50	140	4.94	125	0.280	7	120.00	3048
1100531-3	5.50	140	4.94	125	0.280	7	36.00	914
1100531-5	5.50	140	4.94	125	0.280	7	60.00	1524
1100507-10	6.00	152	5.71	145	0.145	4	120.00	3048
1100507-20	6.00	152	5.71	145	0.145	4	240.00	6096
1100507-3	6.00	152	5.71	145	0.145	4	36.00	914
1100507-5	6.00	152	5.71	145	0.145	4	60.00	1524
1100508-10	8.00	203	7.68	195	0.160	4	120.00	3048
1100508-3	8.00	203	7.68	195	0.160	4	36.00	914
1100508-5	8.00	203	7.68	195	0.160	4	60.00	1524
1100509-10	10.00	254	9.69	246	0.155	4	120.00	3048
1100509-3	10.00	254	9.69	246	0.155	4	36.00	914
1100509-5	10.00	254	9.69	246	0.155	4	60.00	1524
1100509-	10.00	254	9.69	246	0.155	4	78.84	2003
1100515-1	12.00	305	11.67	296	0.165	4	12.00	305
1100515-10	12.00	305	11.67	296	0.165	4	120.00	3048
1100515-3	12.00	305	11.67	296	0.165	4	36.00	914
1100515-5	12.00	305	11.67	296	0.165	4	60.00	1524
1100532-10	12.00	305	11.34	288	0.330	8	120.00	3048
1100514-12	14.00	356	13.66	347	0.170	4	144.00	3658
1100514-3	14.00	356	13.66	347	0.170	4	36.00	914
1100514-6	14.00	356	13.66	347	0.170	4	72.00	1829
1100516-12	16.00	406	15.57	395	0.215	5	144.00	3658
1100529-12	18.00	457	17.63	448	0.185	5	144.00	3658

Parts listed are standard unfinished; for custom color and/or finishes, please contact us.



Exhaust Fittings

Exhaust system fittings are made of the same fiberglass and fire-retardant resin used to produce Vernatube®. The fittings are lightweight, strong, non-corroding, and durable. Fittings are easy to install and O.D.'s are compatible with approved marine rubber exhaust hoses.

STANDARD ELBOW

Standard Elbow 45°				
Part #	A		C	
	Nom O.D.		Length	
	IN	MM	IN	MM
1200733	1.00	25	5.00	127
1200217	1.50	38	7.69	195
1200214	1.63	41	6.00	152
1200281	1.88	48	6.56	167
1200192	2.00	51	5.81	148
1200308	2.38	60	7.19	183
1200215	2.50	64	8.94	227
1200294	2.88	73	8.56	217
1200109	3.00	76	8.56	217
1200111	3.50	89	10.25	260
1200112	4.00	102	10.25	260
1200113	5.00	127	13.69	348
1200114	6.00	152	15.38	391
1200216	8.00	203	19.31	490
1200204	10.00	254	22.44	570
1200311	12.00	305	25.56	649

Standard Elbow 90°				
Part #	A		C	
	Nom O.D.		Length	
	IN	MM	IN	MM
1200376	1.00	25	4.56	116
1200555	1.25	32	3.78	96
1200202	1.50	38	5.06	129
1200201	1.63	41	5.69	145
1200312	1.75	44	6.19	157
1200267	1.88	48	5.63	143
1200200	2.00	51	5.75	146
1200195	2.50	64	6.38	162
1200295	2.88	73	7.44	189
1200171	3.00	76	7.50	191
1200189	3.50	89	10.13	257
1200157	4.00	102	9.38	238
1200175	5.00	127	12.25	311
1200162	6.00	152	13.52	343
1200937	6.00	152	14.00	356
1200197	8.00	203	18.12	460
1200762	8.00	203	18.00	457
1200327	10.00	254	21.83	554
1200817	10.00	254	22.00	559
1200719	14.00	356	28.00	711

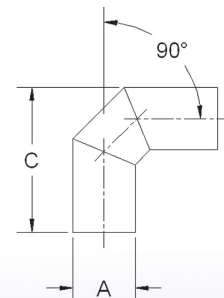
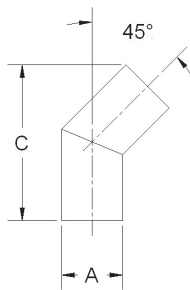

Parts listed are standard unfinished; for custom color and/or finishes, please contact us.

REDUCER ELBOW

Reducer Elbow 45°						
Part #	A1		A2		C	
	Nom O.D.		Nom O.D.		Length	
	IN	MM	IN	MM	IN	MM
1200816	1.50	38	2.00	51	6.25	159
1200496	2.00	51	3.00	76	7.75	197
1200870	2.00	51	2.50	64	7.50	191
1200605	2.25	57	3.00	76	3.00	76
1200468	3.00	76	4.00	102	11.75	298
1200480	3.00	76	3.50	89	6.31	160
1200420	3.50	89	4.00	102	10.38	264
1200642	3.50	89	5.00	127	5.00	127
1200477	6.00	152	8.00	203	17.25	438

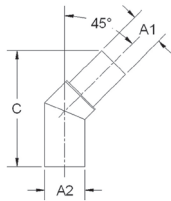

Reducer Elbow 90°						
Part #	A1		A2		C	
	Nom O.D.		Nom O.D.		Length	
	IN	MM	IN	MM	IN	MM
1200570	1.25	32	1.50	38	5.09	129
1200500	1.50	38	2.00	51	6.06	154
1200576	1.63	41	2.00	51	5.77	147
1200454	3.00	76	4.00	102	10.50	267
1200521	3.50	89	4.00	102	10.19	259
1200581	3.50	89	5.00	127	10.88	276
1200531	4.00	102	5.00	127	12.31	313
1200758	4.00	102	4.50	114	12.00	305
1200577	8.00	203	10.00	254	23.00	584

Parts listed are standard unfinished; for custom color and/or finishes, please contact us.

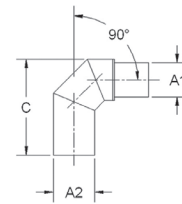

STANDARD FITTINGS

Standard Fitting 45°										
Part #	A1		A2		A3		C		J/H	
	Nom O.D.		Nom O.D.		Nom O.D.		Length		Width/Height	
	IN	MM	IN	MM	IN	MM	IN	MM	IN	MM
1200896	1.50	38	1.50	38	2.00	51	9.00	229	6.00	152
1200981	2.00	51	2.00	51	2.00	51	12.06	306	6.25	159
1200256	3.00	76	3.00	76	4.00	102	14.00	356	9.31	236
1200757	3.00	76	3.00	76	3.50	89	14.00	356	9.50	241
1200978	3.00	76	2.00	51	3.00	76	14.00	356	7.25	184
1200320	3.00	76	3.00	76	5.00	127	14.88	378	10.31	262
1200701	3.50	89	5.00	127	3.50	89	15.00	381	11.51	292
1200755	3.50	89	4.00	102	3.50	89	14.25	362	10.44	265
1200415	3.50	89	3.50	89	4.00	102	16.00	406	10.06	256
1200119	4.00	102	4.00	102	6.00	152	19.19	487	10.00	254
1200304	4.00	102	4.00	102	5.00	127	17.50	445	11.81	300
1200316	4.00	102	4.00	102	4.00	102	16.50	419	11.20	284

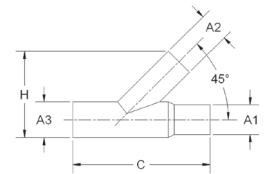

Parts listed are standard unfinished; for custom color and/or finishes, please contact us.

Standard Fitting 90°										
Part #	A1		A2		A3		C		J/H	
	Nom O.D.		Nom O.D.		Nom O.D.		Length		Width/Height	
	IN	MM	IN	MM	IN	MM	IN	MM	IN	MM
1200389	3.00	76	3.00	76	4.00	102	14.00	356	8.00	203
1200498	3.00	76	3.00	76	4.00	102	14.00	356	9.25	235
1200499	3.00	76	3.00	76	5.00	127	17.00	432	10.31	262
1200850	3.00	76	3.00	76	5.00	127	36.25	921	11.5	292
1200373	4.00	102	4.00	102	4.00	102	14.00	356	9.00	229
1200742	4.00	102	4.00	102	5.00	127	15.00	381	11.19	284
1200890	6.00	152	6.00	152	6.00	152	18.00	457	12.00	305

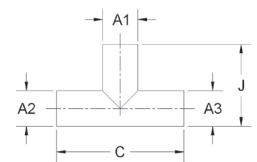

Parts listed are standard unfinished; for custom color and/or finishes, please contact us.

RETURN ELBOW

Part #	A		H		J		Degrees
	Nom O.D.		Height		Width		
	IN	MM	IN	MM	IN	MM	
1200353	1.50	38	5.25	133	4.50	114	180°
1200354	1.63	41	4.00	102	4.88	124	180°
1200333	2.00	51	5.75	146	6.00	152	180°
1200199	3.00	76	7.50	191	8.44	214	180°
1200361	3.50	89	8.75	222	10.50	267	180°
1200334	4.00	102	9.38	238	11.50	292	180°
1200402	5.00	127	12.50	318	15.00	381	180°
1200399	6.00	152	15.00	381	18.06	459	180°
1200370	8.00	203	20.31	516	24.00	610	180°

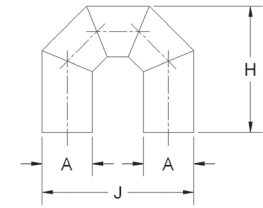

Parts listed are standard unfinished; for custom color and/or finishes, please contact us.

SURGE CHAMBER

Part #	A1		A2		C		H	
	Inlet		Outlet		Length		Height	
	IN	MM	IN	MM	IN	MM	IN	MM
1200442	3.00	76	3.00	76	14.19	360	8.31	211
1200387	3.50	89	3.50	89	15.75	400	9.69	246
1200362	4.00	102	4.00	102	18.00	457	11.06	281
1200363	4.50	114	4.50	114	19.75	502	12.25	311
1200364	5.00	127	5.00	127	21.50	546	13.50	343
1200527	5.00	127	6.00	152	25.00	635	13.94	354
1200604	5.00	127	8.00	203	32.00	813	19.50	495
1200365	6.00	152	6.00	152	25.00	635	16.06	408
1200366	8.00	203	8.00	203	32.00	813	20.94	532
1200367	10.00	254	10.00	254	32.00	813	24.13	613

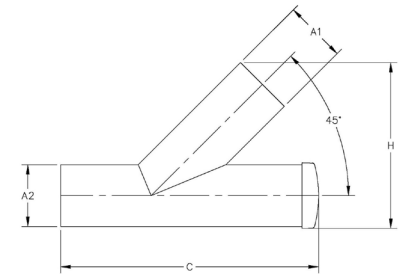

Parts listed are standard unfinished; for custom color and/or finishes, please contact us.

REDUCER COUPLING

Part #	A1		A2		C		Standard Finish
	Nom O.D.		Nom O.D.		Length		
	IN	MM	IN	MM	IN	MM	
1200410	1.50	38	2.00	51	6.19	157	Unfinished
1200266	1.60	40	2.03	52	5.81	148	Bulk Moulding Compound
1200394	1.75	44	2.00	51	6.00	152	Unfinished
1200264	2.00	50	3.00	76	8.00	203	Unfinished
1200277	2.00	50	2.50	64	4.25	108	Bulk Moulding Compound
1200270	2.50	63	3.00	76	8.50	216	Unfinished
1200161	3.00	76	3.50	89	9.50	241	Unfinished
1200170	3.00	76	4.00	102	10.00	254	Unfinished
1200222	3.50	88	4.00	102	10.50	267	Unfinished
1200223	4.00	101	5.00	127	12.00	305	Unfinished
1200265	4.00	101	6.00	152	14.00	356	Unfinished
1200227	4.50	114	5.00	127	12.50	318	Unfinished
1200148	5.00	127	6.00	152	14.00	356	Unfinished
1200166	6.00	152	8.00	203	18.00	457	Unfinished
1200550	6.00	152	6.00	152	6.00	152	Unfinished

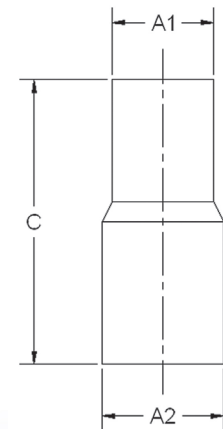

For custom color and/or finishes, please contact us.

Accessories

Centek Marine exhaust accessories are used in conjunction our exhaust systems to manage and expel exhaust gases safely and efficiently. These marine exhaust components include thru hull fittings, crush sleeves, and check valves. All are designed to work in conjunction with Centek Marine exhaust systems and to withstand harsh marine environments.

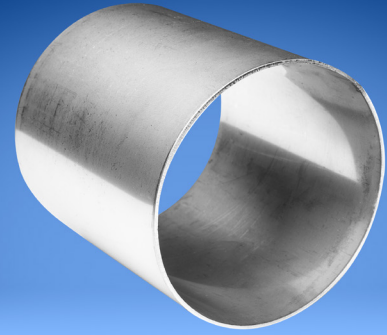

THRU HULL FITTING

Part #	Flap	Color	A		B		C		D		E	
			Nom O.D.		Ext. Length		Length		Diameter		T-H Length	
			IN	MM	IN	MM	IN	MM	IN	MM	IN	MM
1200300-W	Yes	White	2.00	51	1.68	43	4.43	113	3.50	89	2.75	70
1200301-BL	Yes	Black	2.00	51	1.68	43	4.43	113	3.50	89	2.75	70
1200298-W	Yes	White	3.00	76	2.32	59	5.32	135	4.88	124	3.00	76
1200299-BL	Yes	Black	3.00	76	2.32	59	5.32	135	4.88	124	3.00	76
1200422-BL	Yes	Black	4.00	102	1.44	37	6.06	154	6.00	152	4.50	114
1200325-BL	Yes	Black	4.00	102	2.72	69	7.22	183	6.00	152	4.50	114
1200326-W	Yes	White	4.00	102	2.72	69	7.22	183	6.00	152	4.50	114
1200342-W	Yes	White	5.00	127	3.44	87	9.06	230	7.50	191	5.63	143
1200343-BL	Yes	Black	5.00	127	3.44	87	9.06	230	7.50	191	5.63	143
1200302-W	No	White	2.00	51	0.44	11	3.19	81	3.50	89	2.75	70
1200303-BL	No	Black	2.00	51	0.44	11	3.19	81	3.50	89	2.75	70
1200287-W	No	White	3.00	76	0.63	16	3.63	92	4.88	124	3.00	76
1200288-BL	No	Black	3.00	76	0.63	16	3.63	92	4.88	124	3.00	76
1200323-BL	No	Black	4.00	102	0.63	16	5.13	130	6.00	152	4.50	114
1200324-W	No	White	4.00	102	0.63	16	5.13	130	6.00	152	4.50	114

Parts listed are bulk moulding compound.

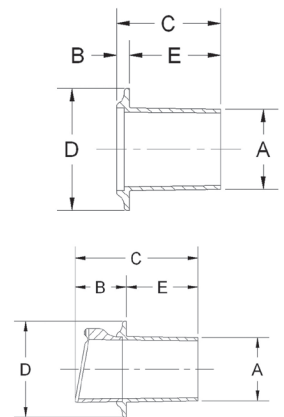

CRUSH SLEEVE

Part #	Nominal O.D.		A		B	
	Sleeve O.D.		Length		Length	
	IN	MM	IN	MM	IN	MM
1200584	4.00	102	3.69	94	4.00	102
1200585	5.00	127	4.67	119	4.00	102
1200586	6.00	152	5.66	144	4.00	102
1200587	7.00	178	7.65	194	4.00	102
1200588	10.00	254	9.65	245	4.00	102
1200589	12.00	305	11.63	295	4.00	102
1200590	14.00	356	13.56	344	4.00	102
1200591	16.00	406	15.52	394	4.00	102

Parts listed are 316L

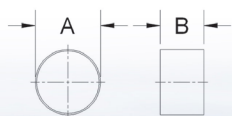

CHECK VALVE

Part #	A		B		C		D	
	Norm. O.D.		I/O Length		Length		Diameter	
	IN	MM	IN	MM	IN	MM	IN	MM
1200403	1.50	38	2.00	51	9.75	248	4.31	109
1200263	1.63	41	2.00	51	9.81	249	4.00	102
1200328	2.00	51	1.69	43	8.37	213	4.00	102
1200449	2.38	60	3.00	76	10.50	267	5.00	127
1200307	2.50	64	3.00	76	10.50	267	5.00	127
1200274	3.00	76	3.00	76	10.50	267	5.00	127
1200411	3.50	89	2.94	75	12.00	305	6.38	162
1200369	4.00	102	3.00	76	12.00	305	6.38	162
1200377	5.00	127	4.00	102	15.00	381	8.38	213
1200386	6.00	152	5.50	140	26.00	660	12.19	310
1200641	6.00	152	3.00	76	18.00	457	10.63	270
1200695	8.00	203	6.00	152	31.62	803	16.21	412

Parts listed are standard black; for custom color and/or finishes, please contact us.

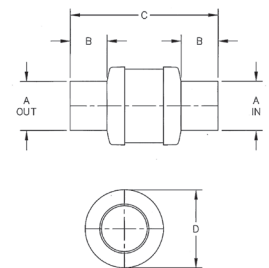



Environmental Products

Centek Marine offers the most innovative and effective solutions to the hydrocarbon pollution discharged overboard from a vessel's bilge or generator. A patented filter medium chemically binds to hydrocarbon molecules and allows the now-clean water to pass through freely. This removes the oily sheen on the water surrounding the boat, leading to a more environmentally friendly and enjoyable boating experience.

BILGE-KLEEN™

The Bilge-Kleen Bilge Water Filter System filters bilge water discharge and removes hydrocarbons without increasing pressure to the bilge pump. The patented Bilge-Kleen automatically removes oil, gas, diesel fuel and other hydrocarbon pollutants from bilge water before it is discharged overboard. Using a special filter medium, the Bilge-Kleen captures and binds to hydrocarbons and lets water pass through freely. As a result, 99.9% of the hydrocarbon pollutants are eliminated from discharge with no increase in pressure to the bilge pump.

Part #	Filter Capacity	Maximum Flow		Dimensions				NPT	Replacement Filter
				Diameter		Height			
		GPM	LPM	IN	MM	IN	MM		
8-MBK-1	> 150 grams	10	38	4.50	114	7.50	191	0.5"	8-M5-1
8-BK-1	> 300 grams	25	95	4.50	114	12.50	318	0.5"	8-BF-1-1R
8-BK-1-DFP	> 600 grams	25	95	4.50	114	12.50	318	0.5"	8-BF-1-1R
8-BK-2	> 900 grams	40	151	7.50	191	14.00	356	1.50"	8-BF-2-1R
8-BK-3	> 1800 grams	50	189	7.50	191	20.00	508	1.50"	8-BF-3-1R



Dry Exhaust

Centek Marine Dry Exhaust can be delivered as one unit or modularly, depending on your installation needs. Components are fabricated out of 304 and 316L stainless steel and hard coated for maximum protection against heat. Each dry exhaust system is custom based on your specifications and comes with flanged connections and mounting hardware for a complete pre-engineered exhaust system package that is ready to install.

Metal Risers

While every Centek Marine metal riser is custom made to each customer's specifications, there are certain characteristics unique to Centek Marine present in each riser we design and manufacture. When paired with Centek's fiberglass exhaust parts, it creates a superior full marine engine exhaust system.



UNIQUE PROPERTIES OF A CENTEK MARINE METAL RISER SYSTEM

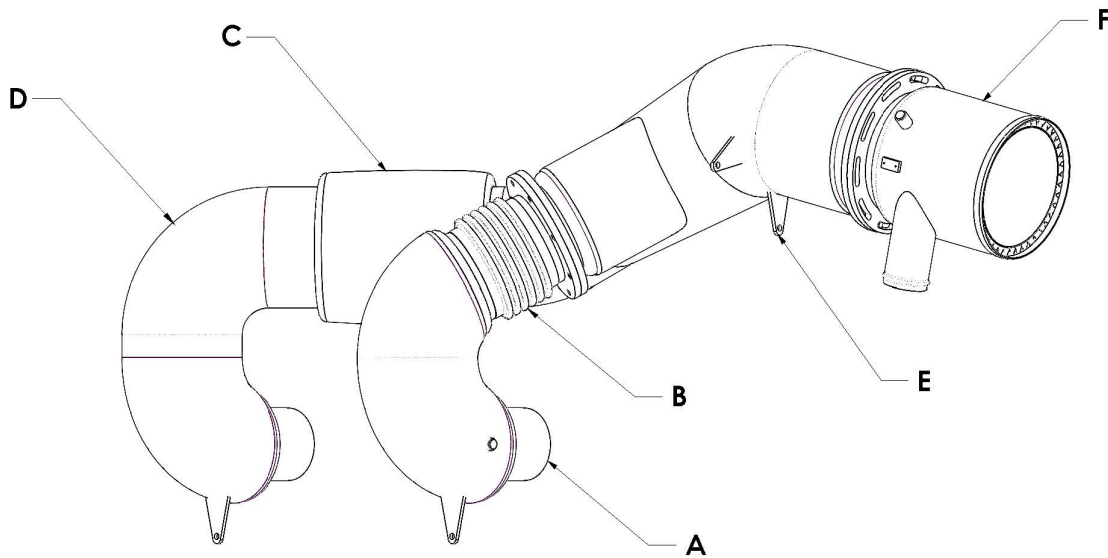

- A. ANSI, Custom, and Turbo flanges are all custom made in-house to ensure proper fit in any engine room.
- B. Engineered bellows are flexible and combat thermal expansion in the riser.
- C. Handmade thermal blankets are tailored to each joint and exposed hotspot.
- D. Proprietary hardcoat coat formula provides a showroom finish that offers the safety of blankets without the continual maintenance.
- E. Proven mounting points and hardware isolate vibration and safely secure the riser in the engine room.
- F. Mixing Tank made with AL6XN alloy and Centek Marine's signature "V Notch" diffuser ensures the longest possible life-cycle with the most efficient gas cooling.

Centek Marine also stocks a variety of gaskets and stanchions in a range of standard sizes. Custom sizes of these products are also available, as well as engine-specific flanges for most major engine models.

GASKETS

Gaskets are constructed using a 1/16" thick graphite with a 316 SS tang reinforcement, which provides radial strength and helps prevent blowouts. This construction offers outstanding resistance against temperature variations and high thermal conductivity.

Part #	I.D.		O.D.		# of Bolts	B.C.		Bolt Hole Diameter		Angle
	IN	MM	IN	MM		IN	MM	IN	MM	
231-100030-05	3.55	90	6.50	165	5	5.55	196	0.438	16	72°
231-100040-06	4.55	116	7.50	191	6	6.50	230	0.438	16	60°
231-100050-06	5.60	142	8.50	216	6	7.50	266	0.438	16	60°
231-100060-08	6.63	168	9.50	241	8	8.50	301	0.438	16	45°
231-100080-08	6.50	165	13.50	343	8	11.75	416	0.88	31	45°
231-100080-10	8.63	219	11.50	292	10	10.50	372	0.438	16	36°
231-100100-12	10.80	274	13.75	349	12	12.75	451	0.437	15	30°
231-100140-18	14.05	357	17.00	432	18	16.00	566	0.438	16	20°
231-100160-14	16.05	408	19.00	483	14	18.00	637	0.438	16	25.71°
231-100180-16	17.85	453	21.45	545	16	20.25	717	0.438	16	22.5°
231-100180-20	18.05	458	21.00	533	20	20.00	708	0.438	16	18°

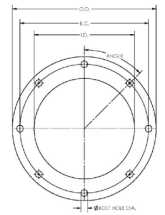

STANCHION KITS

Part #	Minimum Length		Maximum Length	
	IN	MM	IN	MM
350-060100	6.00	152	10.00	254
350-080120	8.00	203	12.00	305
350-100140	10.00	254	14.00	356
350-120160	12.00	305	16.00	406
350-140180	14.00	356	18.00	457
350-160200	16.00	406	20.00	508
350-180220	18.00	457	22.00	559
350-200240	20.00	508	24.00	610
350-220260	22.00	559	26.00	660
350-240280	24.00	610	28.00	711
350-260300	26.00	660	30.00	762
350-280320	28.00	711	32.00	813
350-300340	30.00	762	34.00	864
350-320360	32.00	813	36.00	914
350-340380	34.00	864	38.00	965
350-360400	36.00	914	40.00	1016
350-380420	38.00	965	42.00	1067
350-400440	40.00	1016	44.00	1118
350-420460	42.00	1067	46.00	1168

Stanchion Kits are made from 316L SCH40 pipe and have a brushed finish. Products can be powder coated white or any other color preferred. Centek Marine can also create custom stanchion adapters that can tie into just about any mounting configuration.





Ventilation Systems

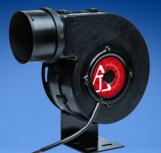

Marine Ventilation systems play several critical roles in an engine room, from airflow to temperature to control to the elimination of moisture.

Proper engine room ventilation has been largely overlooked for years. Most of today's newer vessels lack adequate airflow for optimum engine performance, as the trend across all vessel types is toward larger engines with a greater need for combustion and cooling air. This leaves your vessel subject to

- **Greatly increased maintenance and fuel costs**
- **High restriction and poor performance**
- **Salt and moisture damage**
- **Dangerous heat and noise levels**
- **Auxiliary equipment damage**
- **Engine warranty problems**
- **Catastrophic engine failure**

Through its world-class, globally renowned line of Delta-T Systems ventilation products, Centek Marine offers complete engine room ventilation design from inlet to outlet. Our experienced engineering team maintains an extensive database of heat and air requirements from virtually every marine diesel engine and generator manufacturer along with our own calculations and formulae from over 20,000 installations. Using this information, our expert engineers can design a full ventilation system to meet your vessel's exact specifications.

STUDIES DONE BY THE U.S. COAST GUARD HAVE DETERMINED THAT CENTEK MARINE'S COMPLETE DELTA-T VENTILATION SYSTEMS CAN SAVE UPWARDS OF \$5,000,000 IN TERMS OF FUEL AND ENGINE OVERHAUL EXPENSES OVER THE LIFE CYCLE OF EACH VESSEL IN THE 87CPB FLEET.



The following pages showcase our standard ventilation product capabilities and designs. However, most Delta-T Systems ventilation products are custom engineered to each vessel's requirement. If you do not see what you need, scan this QR code to fill out a form that will go to our engineering team. You may also reach out to our engineering team at +1 229.228.7653 or info@centekmarine.com so we can help you design the optimal system for your vessel.

Marine Fans + Blowers

Purposefully designed for the harsh, marine environment, fans – both large and small – play an integral part in a properly engineered ventilation system. Centek Marine’s extensive line of fans include AC and DC axial fans, and all are robust, highly efficient, and rated for continuous use. Select standard sizes for all our fan types are listed, but our engineers have the ability to design custom sizes to meet your vessel’s exact specifications.



STANDARD MARINE AXIAL FANS

Standard Marine Axial Fans are designed using flanged rolled steel housings. They are epoxy coated to provide excellent durability and corrosion resistance. Fan blades are constructed with a non-corrosive polypropylene composite and are pitch adjustable to allow for a wide range of flows and duties. The high-performance airfoil blade shape provides for exceptional flow characteristics and low sound levels. Major assembly hardware is constructed of corrosion-resistant stainless steel. Standard Marine Axial Fans are built with a high efficiency NEMA Premium three- or single-phase direct drive motor to provide quiet, continuous duty service. These motors are available with “CE” Classification, 50 or 60 HZ and can be provided in nearly any voltage configuration.

Part #	# of Blades	RPM	Fan Size	A		B		C		D		E	F		
				O.D.		Bolt Circle		I.D.		Length			Bolt Holes (x8)		
				IN	MM	IN	MM	IN	MM	IN	MM		IN	MM	
500-412361-25/8	8	3450	12	14.06	357	13.13	333	12.00	305	20	508	4.31	110	0.44	11
500-412361-45/10	10	3450	12	14.06	357	13.13	333	12.00	305	20	508	4.31	110	0.44	11
500-412363-25/8	8	3400	12	14.06	357	13.13	333	12.00	305	20	508	4.31	110	0.44	11
500-412363-40/10	10	3430	12	14.06	357	13.13	333	12.00	305	20	508	4.31	110	0.44	11
500-415183-45/10	10	1750	15	17.06	433	16.13	410	15.00	381	20	508	4.31	110	0.44	11
500-418183-35/10	10	1750	18	20.06	510	19.13	486	18.00	457	20	508	4.81	122	0.44	11
500-418183-45/10	10	1750	18	20.06	510	19.13	486	18.00	457	20	508	4.81	122	0.44	11
500-418363-25/10	10	2880	18	20.06	510	19.13	486	18.00	457	20	508	4.81	122	0.44	11
500-418363-35/10-5	10	3450	18	20.06	510	19.13	486	18.00	457	20	508	4.81	122	0.44	11
500-424183-32.5/9	9	1750	24	26.69	678	25.81	656	24.00	610	21	533	4.81	122	0.44	11
500-424183-45/9	9	1740	24	26.69	678	25.81	656	24.00	610	21	533	4.81	122	0.44	11
500-424183-48.5/9-6	9	1750	24	26.69	678	25.81	656	24.00	610	21	533	4.81	122	0.44	11
500-430183-30/9	9	1750	30	32.69	830	31.75	806	30.00	762	22	559	5.38	137	0.44	11
500-430183-35/9	9	1750	30	32.69	830	31.75	806	30.00	762	22	559	5.38	137	0.44	11
500-430183-40/9	9	1750	30	32.69	830	31.75	806	30.00	762	22	559	5.38	137	0.44	11
500-436183-40/9	9	1750	36	39.25	997	37.88	962	36.00	914	28	711	5.38	137	0.44	11
500-436183-45/9	9	1740	36	39.25	997	37.88	962	36.00	914	28	711	5.38	137	0.44	11

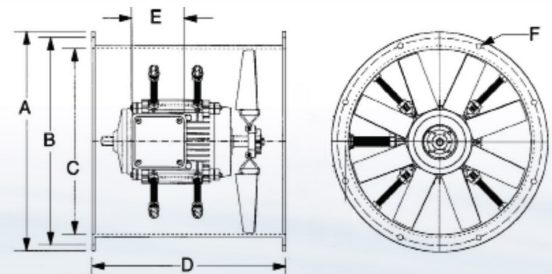



PREMIUM MARINE AXIAL FANS

Premium Marine Axial Fans are made of welded, marine-grade aluminum that provides lightweight and excellent corrosion resistance. Major assembly hardware is corrosion-resistant stainless steel for long life. An external junction box mounted on the housing exterior is provided for electrical connections. High efficiency NEMA Premium three-phase or single-phase direct drive motors are utilized to provide quiet, continuous service. Available with "CE" Classification, 50 or 60 HZ and optional I-EEE-45 Certification, these motors are designed for worldwide applications and can be provided in nearly any voltage configuration. Fan blades are non-corrosive polypropylene composite and allow for a wide range of flows and duties. The high-performance airfoil blade shape provides for exceptional flow characteristics and low sound levels. Premium Marine Axial Fans have a non-overloading characteristic; the peak power input occurs within the range of normal operating pressures and is always exceeded by the motor rating.

Premium Marine Axial Fan Dimensions

Fan Size	A		B		C		D		E		F		G		H		I	
	O.D.		Bolt Circle		I.D.		Length				Bolt Holes						NPT	
IN	IN	MM	IN	MM	IN	MM	IN	MM	IN	MM	IN	MM	IN	MM	IN	MM	IN	MM
12	14.75	375	13.75	349	12.00	305	16.00	406	4.31	110	0.38	10	5.50	140	3.06	78	0.75	19
15	17.75	451	16.75	425	15.00	381	16.00	406	4.31	110	0.44	11	5.50	140	3.06	78	0.75	19
19	21.75	552	20.75	527	19.00	483	16.00	406	4.81	122	0.56	14	6.50	165	3.25	83	0.75	19
21	23.75	603	22.75	578	21.00	533	18.00	457	4.81	122	0.56	14	6.50	165	3.25	83	0.75	19
24	26.75	679	25.75	654	24.00	610	18.00	457	4.81	122	0.56	14	6.50	165	3.25	83	0.75	19
30	33.75	857	32.31	821	30.00	762	28.00	711	5.38	137	0.56	14	7.81	198	4.25	108	1.00	25
36	39.75	1010	38.00	965	36.00	914	28.00	711	5.38	137	0.56	14	7.81	198	4.25	108	1.00	25

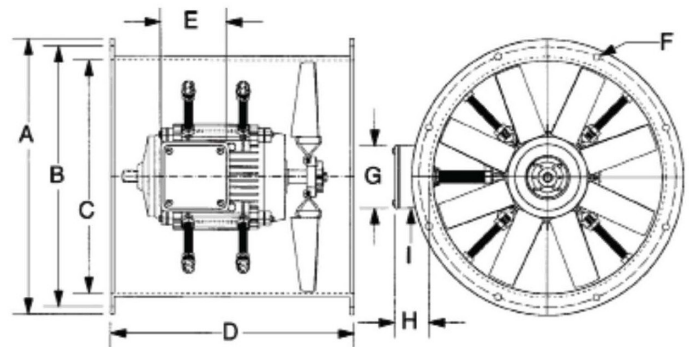

Premium Marine Axial Fan Characteristics							Flow in CFM at Static Pressure in Inches of Water							
Part #	Size	No. of Blades	Motor BHP	Peak AHP	RPM	Free Air	0.25 IN.	0.50 IN.	0.75 IN.	1.0 IN.	1.25 IN.	1.50 IN.	1.75 IN.	2.0 IN.
500-212183-25	12"	8	0.33	0.1	1740	860	650							
500-212183-35	12"	8	0.33	0.1	1740	1210	995							
500-212183-35	12"	10	0.33	0.1	1740	1130	950							
500-212183-45	12"	10	0.33	0.2	1740	1450	1250							
500-212363-30	12"	8	0.75	0.6	3450	2150	2060	1960	1860	1750	1620			
500-212363-35	12"	8	0.75	0.7	3450	2400	2300	2190	2060	1930	1780			
500-212363-40	12"	8	1	1	3450	2800	2680	2560	2420	2270	2080	1850		
500-212363-40	12"	10	1	1.1	3450	2560	2470	2370	2270	2150	2030	1850	1570	
500-212363-45	12"	8	1.5	1.3	3450	3190	3050	2920	2770	2590	2360	2080		
500-212363-45	12"	10	1.5	1.4	3450	2880	2780	2690	2580	2460	2330	2140	1900	
500-215183-30	15"	10	0.33	0.3	1740	2040	1870	1530						
500-215363-25	15"	10	1.5	1.5	3450	3230	3130	3040	2930	2820	2700	2540	2320	
500-215363-30	15"	8	1.5	1.3	3450	4000	3860	3720	3560	3400	3210	2950	2570	
500-215363-30	15"	10	2	1.9	3450	4010	3920	3820	3730	3630	3470	3300	3140	2860
500-215363-35	15"	8	2	1.9	3450	4810	4670	4520	4350	4190	3950	3670	3250	
500-215363-35	15"	10	3	2.3	3450	4700	4600	4490	4380	4270	4110	3910	3650	3370
500-215363-40	15"	8	3	2.3	3450	5510	5330	5160	4980	4770	4530	4250	3900	
500-215363-45	15"	8	3	3	3450	6150	5960	5780	5580	5340	5090	4780		
500-219183-25	19"	10	0.75	0.5	1740	3450	3150	2800	2330					
500-219183-30	19"	10	0.75	0.7	1740	4210	3890	3520	3020					
500-219183-35	19"	10	1	0.9	1740	5190	4870	4490	3920					
500-219183-40	19"	10	1.5	1.3	1740	5960	5600	5180	4590					
500-219183-45	19"	10	1.5	1.7	1740	6760	6300	5830	5250					
500-219363-25	19"	10	3	2.7	3450	6110	6000	5840	5720	5560	5440	5270	5080	4870
500-219363-30	19"	10	5	3.8	3450	7760	7630	7470	7320	7190	7050	6870	6670	6460
500-219363-35	19"	10	5	5.4	3450	9490	9300	9130	8920	8750	8600	8400	8100	7830
500-221183-30	21"	9	2	1.7	1740	6250	5960	5670	5330	4860	4170			
500-221183-32.5	21"	9	2	1.9	1740	6810	6500	6150	5770	5260	4570			
500-221183-35	21"	9	3	2.1	1740	7370	7030	6640	6200	5680	4980			
500-221183-37.5	21"	9	3	2.3	1740	7880	7500	7100	6640	6080	5320			
500-221183-40	21"	9	3	2.6	1740	8400	7980	7540	7080	6450	5640			
500-221183-45	21"	9	3	3.2	1740	9320	8870	8410	7880	7280	6290			
500-224183-25	24"	9	2	1.9	1740	7650	7280	6920	6510	6030	5420	4460	3510	
500-224183-32.5	24"	9	3	3.1	1740	10200	9810	9420	8910	8350	7670	6810	5200	
500-224183-35	24"	9	5	3.5	1740	11200	10700	10300	9700	9110	8380	7520	5860	
500-224183-37.5	24"	9	5	3.7	1740	11900	11500	11000	10400	9800	9030	8050	6340	
500-224183-40	24"	9	5	4.2	1740	12700	12200	12600	11100	10400	9620	8580	6640	
500-224183-45	24"	9	5	5.4	1740	14300	13700	13300	12600	11800	11000	9780	8220	
500-228183-32.5	28"	9	5	4.9	1740	15400	14900	14300	13600	13000	12200	11100	9830	
500-228183-40	28"	9	7.5	7.2	1740	20900	19300	18100	17400	16500	15500	14300	13000	
500-228183-45	28"	9	10	9	1740	22900	21600	20200	19400	18400	17200	15700	14200	
500-230183-30	30"	9	5	5.5	1740	16900	16300	15700	15000	14300	13600	12560	11000	
500-230183-35	30"	9	7.5	7.3	1740	20300	19800	19100	18300	17600	16700	15800	14500	
500-230183-37.5	30"	9	10	8.6	1740	21900	21200	20600	19800	18900	18000	17000	15700	
500-230183-45	30"	9	15	12.1	1740	26500	25700	24800	23800	22800	21600	20200	18700	
500-236183-35	36"	9	15	12.3	1740	30100	29300	28600	27800	26900	25900	24800	23700	
500-236183-37.5	36"	9	15	14.2	1740	33000	32200	31400	30400	29400	28400	27100	25700	
500-236183-40	36"	9	20	16.4	1740	36000	35000	34000	33100	31900	30900	29500	28200	
500-236183-45	36"	9	25	23.4	1740	40900	39900	38900	37800	36700	35600	34200	32800	
500-236183-45	36"	9	25	23.4	1740	40900	39900	38900	37800	36700	35600	34200	32800	



AC AXIAL FANS

AC Axial Fans are ideally suited for small vessel engine rooms and OEM applications where compact ventilation systems are required. These fans provide more than four times the air volume of small AC centrifugal marine blowers with substantial weight savings.

8" AC Axial Fan			
Part #	Fan Size	Voltage	Max Airflow CFM
	IN		
500-208281/1	8.00	115	607
500-208281/2	8.00	230	607

11" AC Axial Fan			
Part #	Fan Size	Voltage	Max Airflow CFM
	IN		
500-211115	11.00	115	1100
500-211230	11.00	230	1100

Fan blades are black powder coated for corrosion resistance. Corrosion-resistant aluminum housings are provided "mill finish" without paint.

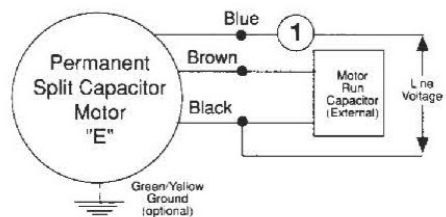
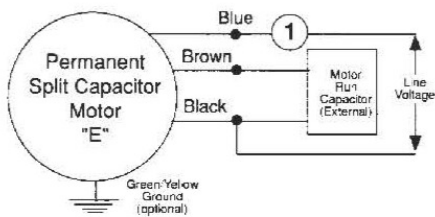
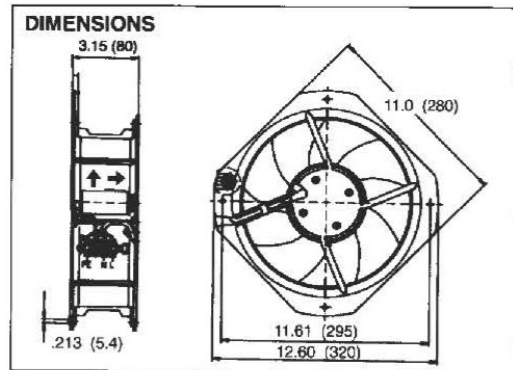
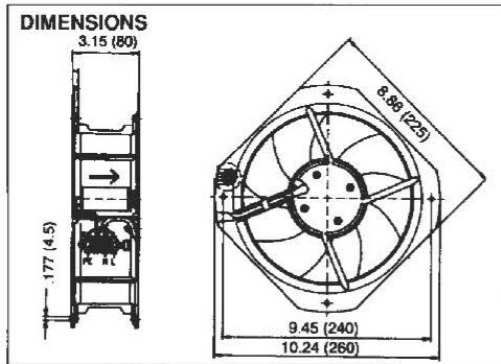



IGNITION PROTECTED DC AXIAL FANS

Ignition Protected DC Axial Fans are specifically designed and built for the marine environment. Made with a flanged glass-filled nylon shroud, this fan provides a nearly indestructible, compact design with superior corrosion resistance. The fan features a 10-blade, glass-filled nylon hub with a pilot secured directly to the motor shaft. The hub/blade assembly can be configured as a pusher or puller fan. The DC Axial Fan is CE compliant, continuous duty rated, and ignition protected, conforming to J1171, ISO 8846 and ISO 9097.

Standard Dimensions

Part #	Fan Diameter		Width		Depth		Height		Voltage	Max Airflows CFM
	IN	MM	IN	MM	IN	MM	IN	MM		
500-309121IP	9.00	229	11.00	279	2.5	64	9.75	248	12v	747
500-309241IP	9.00	229	11.00	279	2.5	64	9.75	248	24v	747
500-311122IP	11.00	279	11.44	291	3.56	90	12.00	305	12v	1400
500-311242IP	11.00	279	11.44	291	3.56	90	12.00	305	24v	1400
500-312122IP	12.00	305	12.72	323	3.29	84	12.72	323	12v	1577
500-312242IP	12.00	305	12.72	323	3.29	84	12.72	323	24v	1619

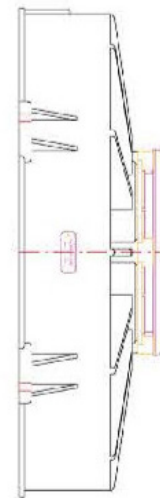
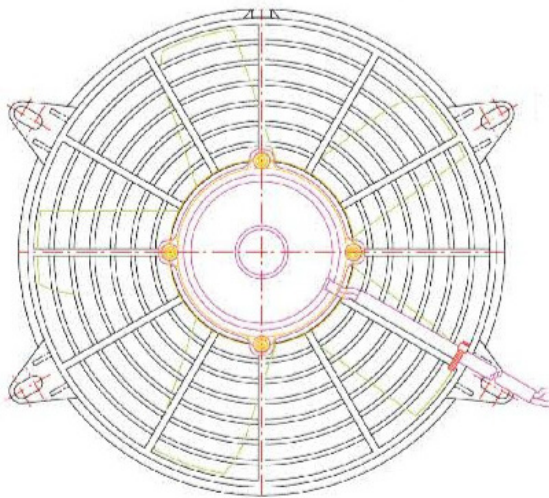



CENTRIFUGAL BLOWERS

Centrifugal Blowers are specifically designed and built for the rigors of the marine environment – not adapted from other industries. With a powder-coated marine grade aluminum housing that uses stainless steel fasteners, these lightweight units provide excellent corrosion resistance. These compact blowers are ideal for OEM applications where a quiet, reliable compact blower is required. Galley fume extraction, head air extraction, engine room ventilation, and interior make up air systems are just a few of the potential applications. Motors of certain models are available with CE Classification and/or optional I-EEE-45 Certification.

4" DC Centrifugal Blower	
Part #	Voltage
500-304121	12v
500-304242	24v

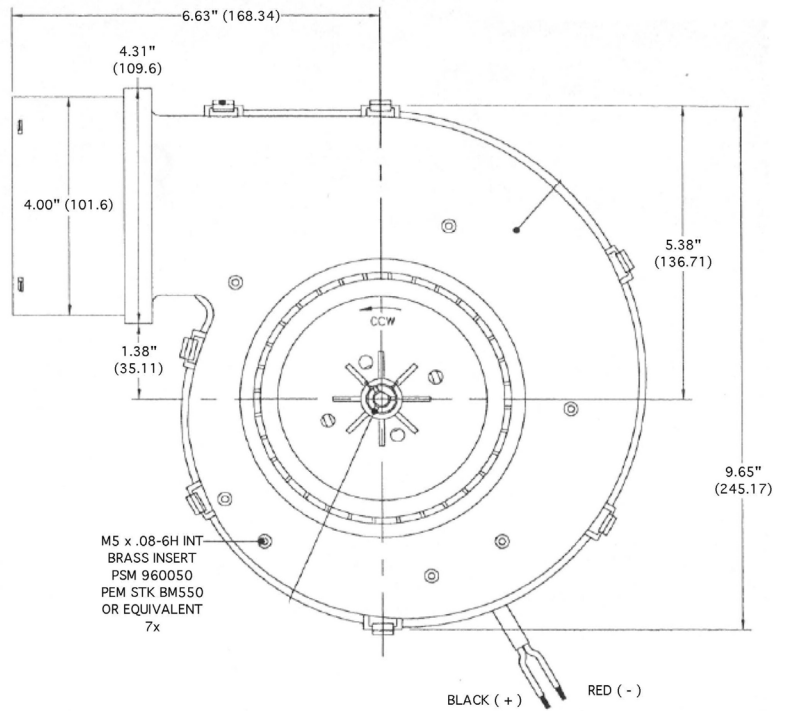
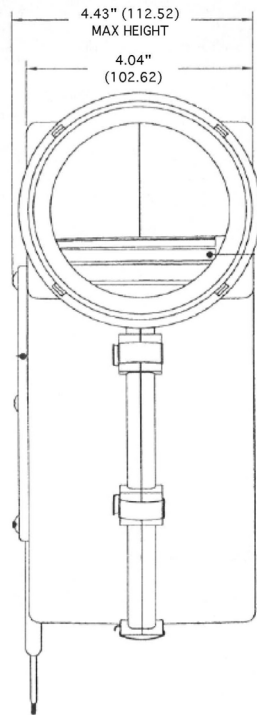

6" AC Centrifugal Blower

Part

500-SC600/1-18CW

500-SC600/1-36CCW

500-SC600/1-36CW

500-SC600/3-18CCW

500-SC600/3-28CCW

500-SC600/3-36CCW

500-SC600/3-36CW

500-SC600/3-36CW-XP

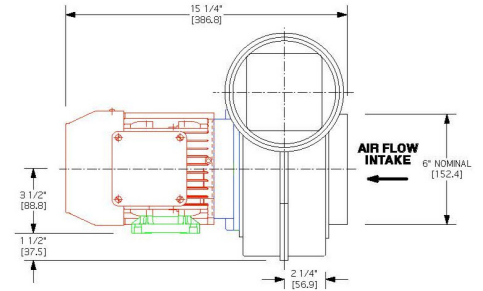
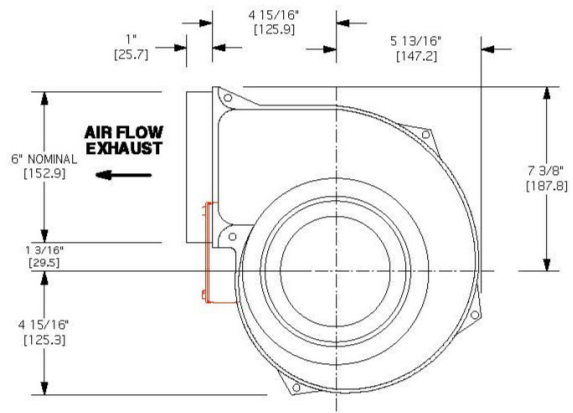

SIDE VIEW
(FIG. 1. CW, TH ORIENTATION SHOWN)

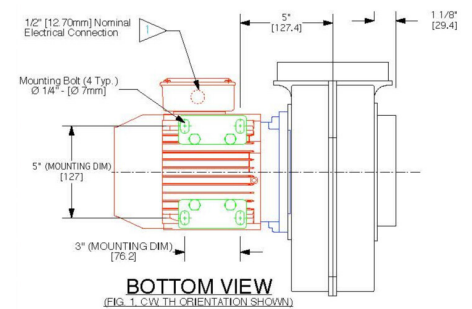

BOTTOM VIEW
(FIG. 1. CW, TH ORIENTATION SHOWN)

8" AC Centrifugal Blower

Part

500-SC800/3-18CCW

500-SC800/3-18CW

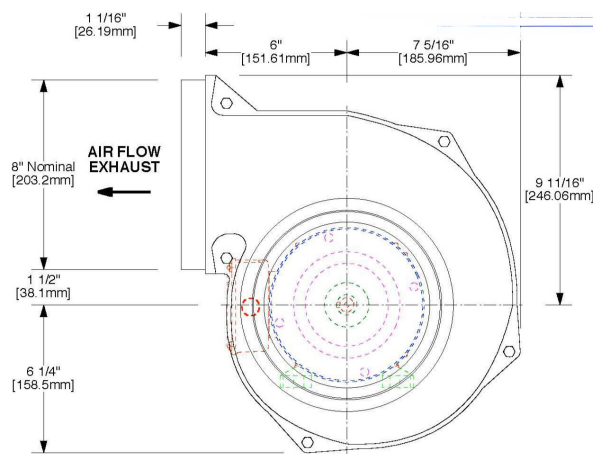

INTAKE END VIEW
(FIG. 1. CW, TH ORIENTATION SHOWN)

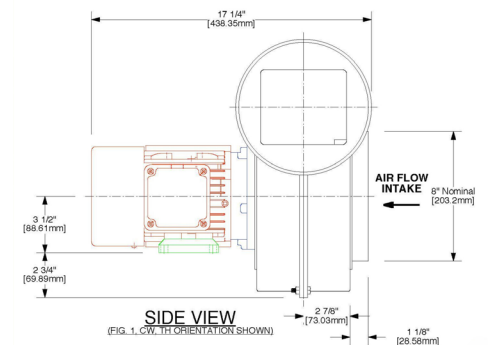

SIDE VIEW
(FIG. 1. CW, TH ORIENTATION SHOWN)

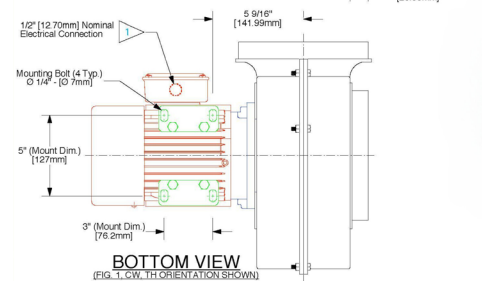

BOTTOM VIEW
(FIG. 1. CW, TH ORIENTATION SHOWN)



INLINE AC DUCT FANS

Inline AC Duct Fans are extremely versatile and feature a rugged plastic housing constructed of UL-recognized, UV-protected thermoplastic resin for the ultimate in lightweight, corrosion-proof inline applications. This tough, protective shell allows the fan to be mounted in wet locations onboard a vessel. Inline fans are ideal for multiple point exhaust, dual head exhaust, or other marine applications.

Inline fan benefits include the following:

- Prewired and supplied with a mounting bracket for easy installation
- Easy connection using external wiring box with waterproof gasket
- 4" to 10" duct diameters
- 100% speed controllable
- Approved for wet locations
- Suitable for airstream temperatures up to 140° F
- Flow rates of 122-649 CFM

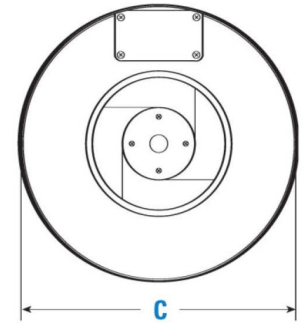
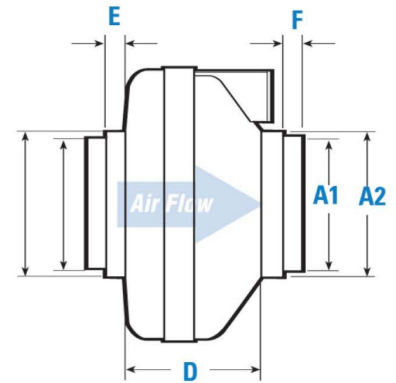

Measurements

Part #	A1		A2		C		D		E		F	
	IN	MM	IN	MM	IN	MM	IN	MM	IN	MM	IN	MM
500-804XL	4.00	102	5.00	127	9.5	241	6.13	156	0.88	22	0.88	22
500-806XL	6.00	152	6.25	159	11.75	298	5.88	149	1.00	25	0.88	22
500-808XL	8.00	203	10.00	254	13.25	337	6.25	159	1.50	38	1.50	38
500-810XL	-	-	10.00	254	13.25	337	6.25	159	1.50	38	-	-

Performance

Part #	Energy Star	RPM	Voltage	Rated Watts	Max Amps	Static Pressure in Inches W.G.							Max PS
						0"	0.2"	0.4"	0.6"	0.8"	1.0"	1.5"	
500-804XL	x	2900	115	19	0.18	122	100	78	55	15	-	-	0.87"
500-806XL	x	2750	120	71	0.67	263	230	198	167	136	106	17	1.58"
500-808XL	x	3100	115	137	1.35	429	400	366	332	297	260	168	2.48"
500-810XL		2850	115	241	2.40	649	600	553	506	454	403	294	2.58"

FAN GUARDS

Fan Guards are a highly recommended option on Delta T Systems high-output axial fans in order to prevent debris and other foreign matter from entering the fan. Fan guards are available in all standard fan sizes and are constructed of either aluminum or steel.

Aluminum Axial Fan Guards		
Part #	IN	MM
510-IG12	12	305
510-IG19	19	483
510-IG21	21	533
510-IG24	24	610
510-IG28	28	711
510-IG30	30	762
510-IG36	36	914

Steel Axial Fan Guards		
Part #	IN	MM
510-IG12S	12	305
510-IG18S	18	457
510-IG24S	24	610
510-IG30S	30	762
510-IG36S	36	914

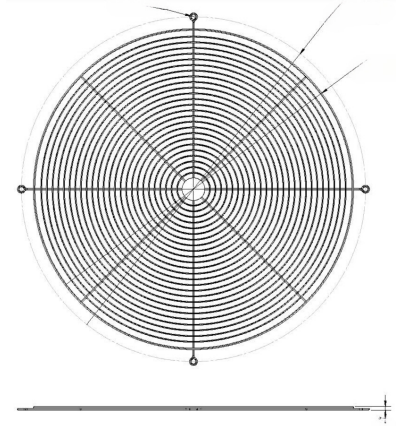

AIRFLOW DIVERTERS

Airflow Diverters are used to guide the intake air for the engine room to the proper locations. This feeds the engines with an ample supply of combustion air and efficiently cools the engine room to the engine manufacturer's specifications. Diverters function to split a single column of intake air that the intake fans are bringing into the engine room into two or three separate columns of air and then redirect those columns to places in the engine room where they are most needed.

Part #	Fan Size (IN)
515-ID08-T2	8
515-ID12-T2	12
515-ID12-T2-PC	12
515-ID12-T2P	12
515-ID12-T3	12
515-ID12-T4	12
515-ID19-T2-PC	19
515-ID21-T4	21
515-ID24-T2	24
515-ID24-T2-PC	24
515-ID24-T3	24
515-ID24-T3-PC	24
515-ID24-T4	24
515-ID24-T4-PC	24

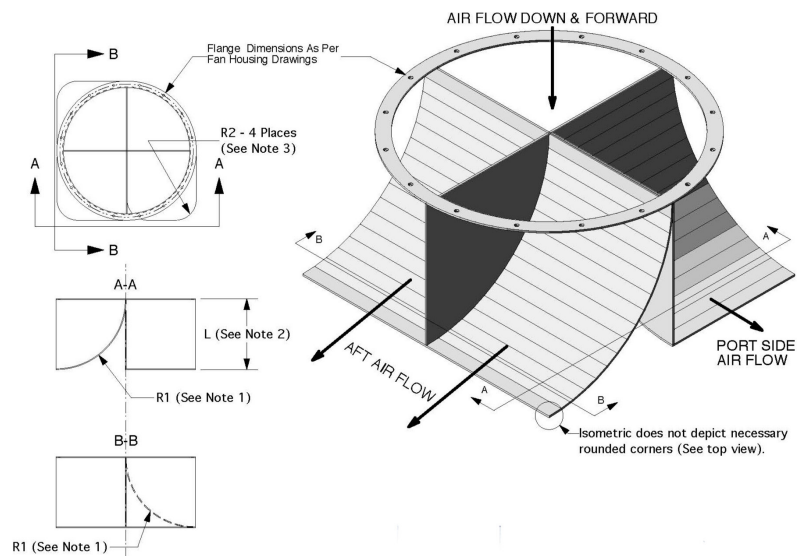



Fire Dampers

Fire Dampers are a crucial part of any ventilation system, as they can provide nearly instantaneous closure of the ventilation system in the event of a fire system discharge. This prevents the dilution of the extinguishing agent and deprives the engine room of oxygen to help quell the fire faster.

SLIMLINE A60 RATED FIRE DAMPERS

- All 316 stainless steel construction
- US Coast Guard and MED approved
- Fully assembled and ready to install
- Patented overlapping blades and locking mechanism
- Failsafe operation
- Include pre-wired thermal sensor and test switch installed on mounting bracket

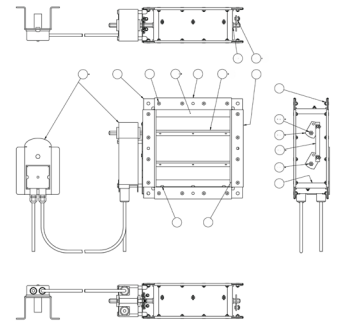

STANDARD RECTANGULAR DAMPERS

- The frame and blades are made from anodized marine grade aluminum; the remaining components are all made from stainless steel for maximum corrosion resistance.
- Closures may use either pneumatic or electric actuators. Electric actuators are available in both AC and DC power.
- All linkage and side seals are precision-crafted from marine grade stainless steel for maximum service life and dependability in the harsh offshore environment.
- Dampers are provided with standard clear anodizing. Powder coating is available and is often used to add further protection against the elements and to enhance aesthetic appeal.

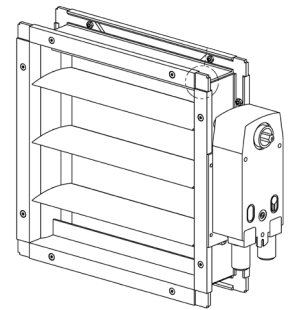

ROUND DAMPERS

- The frame and blades are marine grade aluminum. The remaining components are all made from stainless steel for maximum corrosion resistance.
- Closure of the standard round dampers may use either pneumatic or electric actuators. Electric actuators are available in both AC and DC power.
- All linkage and side seals are precision crafted from marine grade stainless steel for maximum service life and dependability in the harsh offshore environment.
- Dampers are provided with standard mill finish. Powder coating is available and is often used to add further protection against the elements and to enhance aesthetic appeal.

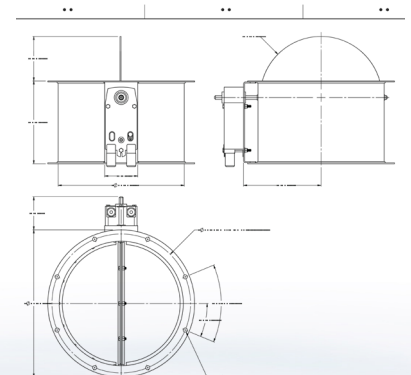

A60 Rated Fire Damper Dimensions

Part #	Damper Blade				Frame			
	Width		Height		Width I.D.		Height I.D.	
	IN	MM	IN	MM	IN	MM	IN	MM
700-A60SL-09	9.00	229	9.00	229	9.38	238	9.38	238
700-A60SL-0912	9.00	229	12.00	305	9.38	238	12.38	314
700-A60SL-0914	9.00	229	14.00	356	9.38	238	14.38	365
700-A60SL-0920	9.00	229	20.00	508	9.38	238	20.38	518
700-A60SL-0946	9.00	229	46.00	1168	9.38	238	46.75	1187
700-A60SL-1209	12.00	305	9.00	229	12.38	314	9.38	238
700-A60SL-12	12.00	305	12.00	305	12.38	314	12.38	314
700-A60SL-1246	12.00	305	46.00	1168	12.38	314	46.75	1187
700-A60SL-1409	14.00	356	9.00	229	14.38	365	9.38	238
700-A60SL-14	14.00	356	14.00	356	14.38	365	14.38	365
700-A60SL-1423	14.00	356	23.00	584	14.38	365	23.38	594
700-A60SL-1427	14.00	356	27.00	686	14.38	365	27.38	695
700-A60SL-1432	14.00	356	32.00	813	14.38	365	32.75	832
700-A60SL1437	14.00	356	37.00	940	14.38	365	37.75	959
700-A60SL-1709	17.00	432	9.00	229	17.38	441	9.38	238
700-A60SL-1720	17.00	432	20.00	508	17.38	441	20.38	518
700-A60SL-1723	17.00	432	23.00	584	17.38	441	23.38	594
700-A60SL-1734	17.00	432	34.00	864	17.38	441	34.75	883
700-A60SL-1740	17.00	432	40.00	1016	17.38	441	40.75	1035
700-A60SL-1746	17.00	432	46.00	1168	17.38	441	46.75	1187
700-A60SL-18	18.00	457	18.00	457	18.38	467	18.38	467
700-A60SL-2009	20.00	508	9.00	229	20.38	518	9.38	238
700-A60SL-2012	20.00	508	12.00	305	20.38	518	12.38	314
700-A60SL-2014	20.00	508	14.00	356	20.38	518	14.38	365
700-A60SL-2017	20.00	508	17.00	432	20.38	518	17.38	441
700-A60SL-20	20.00	508	20.00	508	20.38	518	20.38	518
700-A60SL-21	21.00	533	21.00	533	20.38	518	46.75	1187
700-A60SL-2314	23.00	584	14.00	356	23.38	594	14.38	365
700-A60SL-2317	23.00	584	17.00	432	23.38	594	17.38	441
700-A60SL-2320	23.00	584	20.00	508	23.38	594	20.38	518
700-A60SL-23	23.00	584	23.00	584	23.38	594	23.38	594
700-A60SL-2327	23.00	584	27.00	686	23.38	594	27.38	695
700-A60SL-2340	23.00	584	40.00	1016	23.38	594	40.75	1035
700-A60SL-25	25.00	635	25.00	635	23.38	594	25.38	645
700-A60SL-27	27.00	686	27.00	686	27.38	695	27.38	695
700-A60SL-2714	27.00	686	14.00	356	27.38	695	14.38	365
700-A60SL-2717	27.00	686	17.00	432	27.38	695	17.38	441
700-A60SL-2720	27.00	686	20.00	508	27.38	695	20.38	518
700-A60SL-28	28.00	711	28.00	711	28.75	730	28.75	730
700-A60SL-2846	28.00	711	46.00	1168	28.75	730	46.75	1187
700-A60SL-31	31.00	787	31.00	787	31.75	806	31.75	806
700-A60SL-32	32.00	813	32.00	813	32.75	832	32.75	832
700-A60SL-34	34.00	864	34.00	864	34.75	883	34.75	883
700-A60SL-3446	34.00	864	46.00	1168	34.75	883	46.75	1187
700-A60SL-3913	39.00	991	13.00	330	39.75	1010	13.38	340
700-A60SL-4030	40.00	1016	30.00	762	40.75	1035	30.75	781
700-A60SL-46	46.00	1168	46.00	1168	46.75	1187	46.75	1187
700-A60SL-4631	46.00	1168	31.00	787	46.75	1187	31.75	806

This list of dampers is not exhaustive; our experienced team can design custom and manufacture to any required opening or air trunk.



Moisture Eliminators and Moisture Rejection Closures

Moisture Eliminators are an impingement-type separator designed for vertical installation and horizontal airflow. The individual profiles are designed with a unique 'hook and vane' internal profile that allows proper airflow into the engine room and is over 97% effective at eliminating salt spray and water from airflow. The louvers are available in plastic or aluminum, and powder coating is available on all aluminum products.

MOISTURE ELIMINATOR

Each Moisture Eliminator is custom-designed for the specific application's size and airflow requirements and can be created in any shape or size. The profile packs can be used as a single stage for optimum pressure drop characteristics with good particle separation (10-20 Micron range) or in multiple stage systems using a coalescing material to optimize the particle separation (1-10 Micron range). Delta-T Systems pioneered this technology and design nearly 30 years ago and is the global leader in this application today.

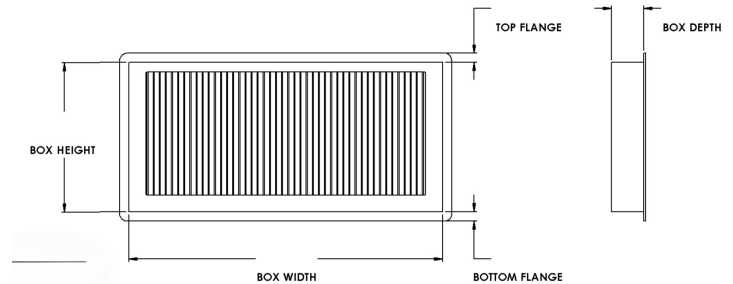
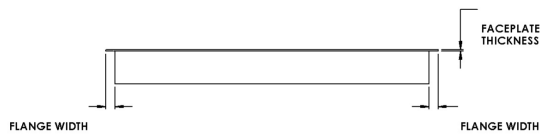

MOISTURE REJECTION CLOSURE

Rough weather may also necessitate closure devices that still allow air to flow. MRC (Moisture Rejection Closure) equipment has an airfoil design that reduces pressure drop and maximizes moisture removal of up to 99.3%.

Mounted in the intake and exhaust openings of the engine room, Moisture Rejection Closures are 6" (152mm) deep and comply with U.S. Coast Guard 46 CFR 116.610 (b) requirements. Manufactured of aluminum and stainless steel, the closures may be opened and closed electronically and manually.

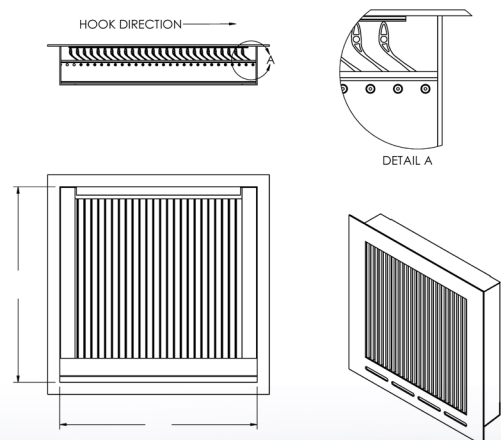

Ventilation Systems

Ventilation controls are designed as a complete engine room ventilation system for use in vessels with an engine space that is well sealed from the interior accommodation spaces. They are designed to work with Delta-T Systems fans and blowers.



VENTILATION CONTROL SYSTEMS

Ventilation control systems are designed to control intake and exhaust fans in the engine room based on the pressure and/or temperature readings to provide the combustion air needs of the vessel's engines. See the table below for the characteristics of each control system.

Part #	Manual v. Automatic	Temperature Sensor	Pressure Sensor	Variable Frequency	Touch Screen Interface
600-MAC	Manual	No	No	Yes	Yes
600-TAC	Both	Yes	No	Yes	Yes
600-PTAC	Both	Yes	Yes	Yes	Yes

*Variable Frequency Drive Options		
Supply voltage	Phase Engine	Temperature Sensor
200 -240 volt	single phase	No
208-240 volt	three phase	Yes
380-480 volt	three phase	Yes

The PTAC comes with a state-of-the-art remote-mounted screen, providing you with unmatched convenience. Mount the screen anywhere in your boat and take full control of the climate settings from anywhere on board. Set your desired temperature, adjust the fan speed, and customize the air distribution effortlessly with just a few taps on the intuitive interface.



The exhaust fan(s) speed is adjusted automatically as the temperature increases, measured by a sensor located within the engine room. The intake fan(s) speed is controlled by an engine room pressure sensor.

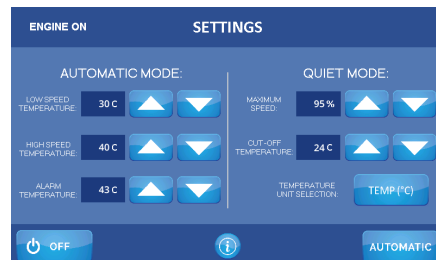

Upon main engine shut down, Quiet Run Mode is activated. This cools the engine room with fans running at a user-specified fixed speed. Once the temperature is below the user-specified temperature, the fans will stop, lowering noise and electrical load levels.

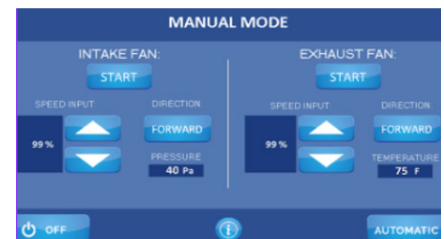

In manual mode, you have complete authority over the system. Adjust the fan speed for intake and exhaust fan individually, ranging from 20% to 100%. You can also select the direction of rotation for each fan and start or stop them as needed.



HEAD VENT SYSTEMS

Head Vent Systems provide simple, cost effective, ventilation of the heads or other small spaces on board a vessel. It provides quiet and efficient air extraction using a single, remotely located blower to extract stale air from multiple locations. It is a self-contained 24-volt unit that houses a quiet, high flow fan and duct manifold inside one central plenum box - which is connected to up to 4 head compartments. The Head Vent System can be configured in both manual and automatic versions.

Part #

600-HVS-24W

The benefits of the Head Vent System over the standard head-ventilating fan include the following:

- Option for fully automatic operation
- Very cost effective - a single, quiet, 350 ft³/min blower is remotely located
- The Head Vent System is much more powerful and effective than standard head fans
- A single exhaust duct means only one vent hole leaving the boat
- Compact plenum box contains all major components in one easy-to-install package



DC FAN CONTROL SYSTEMS

DC Fan Control Systems are designed to automatically control engine room ventilation via a two-temperature setting while still having the convenience of manual low- and high-speed control. In addition to two voltage settings, the DC Fan Control System also provides adjustable temperature systems with two adjustable set points for making easy, on-the-fly adjustments for different climates. The system design allows for a reduction in noise levels and reduces the current draw by up to 25%.

System Advantages		Technical Specifications		Part #	Voltage
Efficient Automatic Operations		Max Current Per Fan: 10 amps each		600-DCT2-12	12v
Two Speed Manual Control (High or Low)		Max Current Total: 40 amps		600-DCT2-24	24v
Reduced Noise Levels		Max Number of Fans: Two or Four*			
Reduced Current Draw		<i>*The 12 VDC Version of the 600-DTC2 must run either 9" fans or 4" blowers only</i>			



Cranston-Eagle *Hooks*

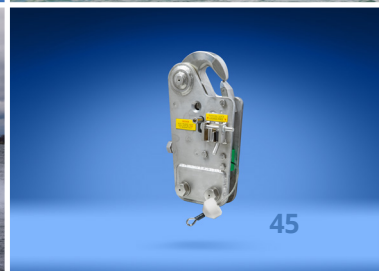
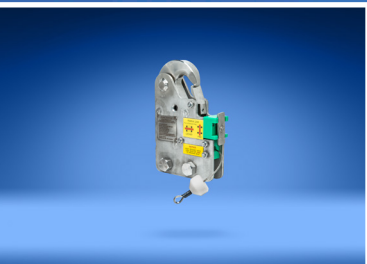

Cranston-Eagle Marine Hooks

Centek Marine is the only Authorized Agent in the U.S., Central, and South America for Cranston-Eagle marine off-load hooks, including parts, rebuilds, load testing, and the required recertification services. Cranston-Eagle marine hooks are among the most trusted in the world. Used extensively by foreign and domestic navies, Coast Guards, research vessels and offshore platforms, these hooks offer operators the split-second release control often needed at sea, including a self-locking feature which prevents release while under full load. Each new hook is proof loaded to 2.2 x SWL/WLL per SOLAS regulations and then inspected and tested for proper operation. Manufacturer's test certificate, signed by a certified surveyor, is included in each delivery.

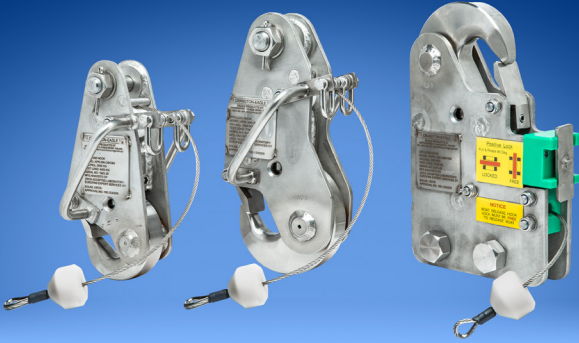

CRANSTON-EAGLE BOAT-MOUNTED MARINE OFF-LOAD RELEASE HOOKS

Cranston-Eagle boat-mounted marine off-load release hooks are used to launch and recover RHIBs and other small craft or marine applications. These models have been tested to six times their rated capacity and are made entirely from marine-grade stainless steel for extended service life and ultimate reliability in the marine environment.

200-70-DPR-856-C4B

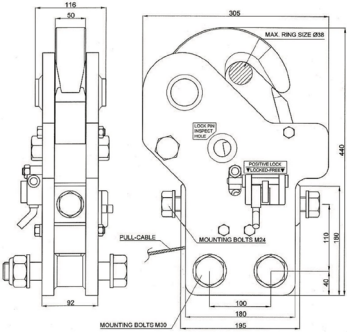

"C-E" Marine Hook, Off-Load Type
Model: 200-70-DPR-856-C4B
 Cable Release, Boat Mounting
 with 4 bolts (included).
SWL/WLL: 8500 kg (6:1)
Weight: 47 kg
 Fitted with positive lock feature.

200-60-APR-456-C3B

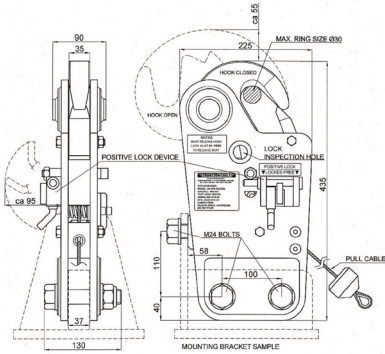

"C-E" Marine Hook, Off-Load Type
Model: 200-60-APR-456-C3B
 Cable Release, Boat Mounting
 with 3 bolts (included).
SWL/WLL: 4500 kg (6:1)
Weight: 26 kg
 Fitted with positive lock feature.



CRANSTON-EAGLE DAVIT MOUNTED OFF-LOAD HOOKS

Cranston-Eagle Davit Mounted Off-Load Hooks are used to launch and recover fast rescue craft and other marine applications. These are US Coast Guard Certified and have been tested to six times their rated capacity and are made entirely from marine-grade stainless steel for extended service life and ultimate reliability. The boat-mounted hooks feature an extremely robust welded frame and bolt-on components; the CBH model is fitted with two handles and tag line shackles. The release mechanism is actuated with a pull cable.

200-APR-206-CBH

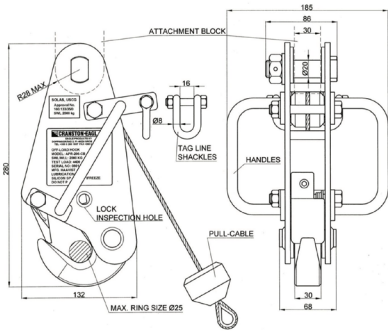

CRANSTON-EAGLE
MARINE HOOKS

“C-E” Marine Hook, Off-Load Type
Model: 200-APR-206-CBH
Cable Release, Top Bolt Mounting
SWL/WLL: 2000 kg (6:1)
Weight: 6.5 kg



USCG Approval Number
160.133/35/0

200-APR-356-CBH

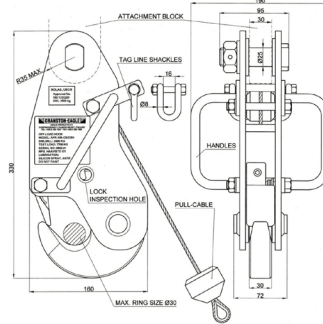

CRANSTON-EAGLE
MARINE HOOKS

“C-E” Marine Hook, Off-Load Type
Model: 200-APR-356-CBH
Cable Release, Top Bolt Mounting
SWL/WLL: 3500 kg (6:1)
Weight: 10.5 kg



USCG Approval Number
160.133/22/0

200-ZAPR-356-C2B-VMX

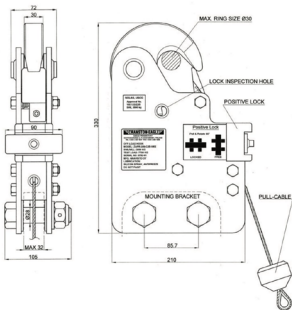

CRANSTON-EAGLE
MARINE HOOKS

“C-E” Marine Hook, Off-Load Type
Model: 200-ZAPR-356-C2B-VMX
Cable Release, Boat Mounting
SWL/WLL: 3500 kg (6:1)
Weight: 13.5 kg
Fitted with positive lock feature.



USCG Approval Number
160.133/22/0

200-DPR-506-CBH

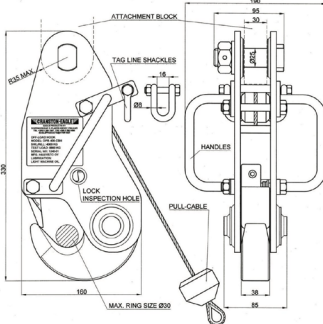

CRANSTON-EAGLE
MARINE HOOKS

“C-E” Marine Hook, Off-Load Type
Model: 200-DPR-506-CBH
Cable Release, Top Bolt Mounting
SWL/WLL: 5000 kg (6:1)
Weight: 11 kg



USCG Approval Number
160.133/77/0

WARRANTY - FIBERGLASS PRODUCTS

Centek Industries, Inc. (Centek) warrants its standard products; Vernatone™, Vernalift™, MiniMax™, Verna-Ski™, Vernatube™, Gen-Sep™, Combo-Sep™, Marlin™ (Products), and its custom designed fiberglass products (Products) for a period of five years from the date of original sale. Since Centek cannot exercise control over the installation and application of the Products, this limited warranty is in lieu of all other expressed or implied warranties such as warranty of merchantability or fitness for a particular use or the results or effects of such use. Under no circumstances will Centek be liable for any consequential damages, damage by improper handling, damage during installation or damage in shipping. Further, Centek encourages customers to perform their own inspection of Products prior to use or installation.

WARRANTY - RISERS AND ASSOCIATED COMPONENTS

No repairs due to an accident, misuse, misapplication, storage damage, negligence or modification exceeding the Centek's specifications are covered by this warranty. Under no circumstances will Centek be liable for any consequential damages, damage by improper handling, damage during installation or damage in shipping. Exhaust system failures as a result of improper or lack of support are not covered under warranty. Centek Industries, Inc. will not replace or repair under warranty any permanent hard coat insulated component on which the adjacent blankets or flange cuffs were improperly installed and overlapped the hard coat insulation.

Item	Period
Stainless Steel Dry Pipe (304 or 316) with AL6XN Mixing Tank	5 Years
Inconel 625 Components	7 Years
90-10 Copper Nickel Raw Water Systems	3 Years
Multi-Ply Expansion Joints	1 Year
Single-Ply Expansion Joints/Flex Tubing	6 Months
Removable Insulation Blankets	1 Year
Permanent Hardcoat Insulation	3 Years

From time to time, Centek, at its sole discretion, may authorize qualified third parties to repair Products. In these rare instances, Centek will have direct communication with repairing party and must provide authorization in writing before any repairs take place. When repairs are authorized, Centek's liability shall not exceed the original purchase price of Product being repaired.

Centek must authorize the return of any alleged defective Product, and such return must be made within 30 days of the receipt of that authorization. A reasonable proof of purchase date must accompany all returned products.

Centek's liability is limited to the replacement or repair of the Products and such liability will not exceed the original purchase price.

WARRANTY – VENTILATION PRODUCTS

- Standard and custom ventilation products sold and/or manufactured under the Delta-T Systems, Inc. brand are warranted by Centek Industries, Inc. (“Centek”) to be free from defects in material and workmanship for a period of 12 months from shipment.
- Upon Centek’s approval, the warranty may be extended to 12 months from commissioning date, but in no instance shall the period of warranty be longer than 18 months from the date of the original shipment date.
- Centek will furnish replacement material or, at its option, repair any product that is proven to Centek’s satisfaction to be defective in materials or workmanship during the warranty period.
- To determine defects, Centek may require material claimed defective to be returned freight prepaid to Centek.
- System components that are not manufactured by Centek will carry the warranty issued by manufacturer.
- Centek shall have no responsibility for the operation or performance of any products in any manner other than that which the product is usually tested and applied under industry standards, nor to any damage to a product from abuse, misapplication, unauthorized repairs, abrasion, erosion, corrosion or the like due to abnormal temperatures, or the influence of foreign matter, nor for the design or operation of any system of which any product may be a part, or for the suitability of any product for any particular application.
- Under no circumstances will Centek be responsible for system functionality unless the entire system has been designed and engineered by Centek and components are supplied by Centek and installed as designed.
- Centek shall not be liable for any cost or expense, including without limitation, labor expenses, in connection with removal or replacement of alleged defective equipment or any part or portion thereof nor for incidental or consequential damages of any kind, or under any circumstances for damage beyond the price of the goods sold.
- **Limitation of Liability:** In no event shall Centek, the Delta-T Systems brand, or its subcontractors or vendors be liable in contract, tort, warranty, strict liability or other legal theory for any special, indirect, incidental or consequential damages such as, but not limited to, loss of anticipated profits or revenues, nonoperation or increased expense of operation of other equipment, or cost of capital. The remedies set forth herein are exclusive and the liability of Centek with respect to any contract or anything done in connection herewith or from the manufacture, sale, delivery, repair, replacement or use of its products covered by or furnished hereunder, whether by contract, tort, warranty, strict liability or other legal theory shall not exceed the purchase price of the product upon which liability is based.

THE FOREGOING WARRANTIES ARE EXCLUSIVE AND IN LIEU OF ALL OTHER WARRANTIES EXCEPT THAT OF TITLE, WHETHER WRITTEN, ORAL OR IMPLIED, IN FACT OR IN LAW (INCLUDING ANY WARRANTY OF MERCHANTABILITY OR FITNESS FOR PARTICULAR PURPOSE).



CEN TEK

MARINE

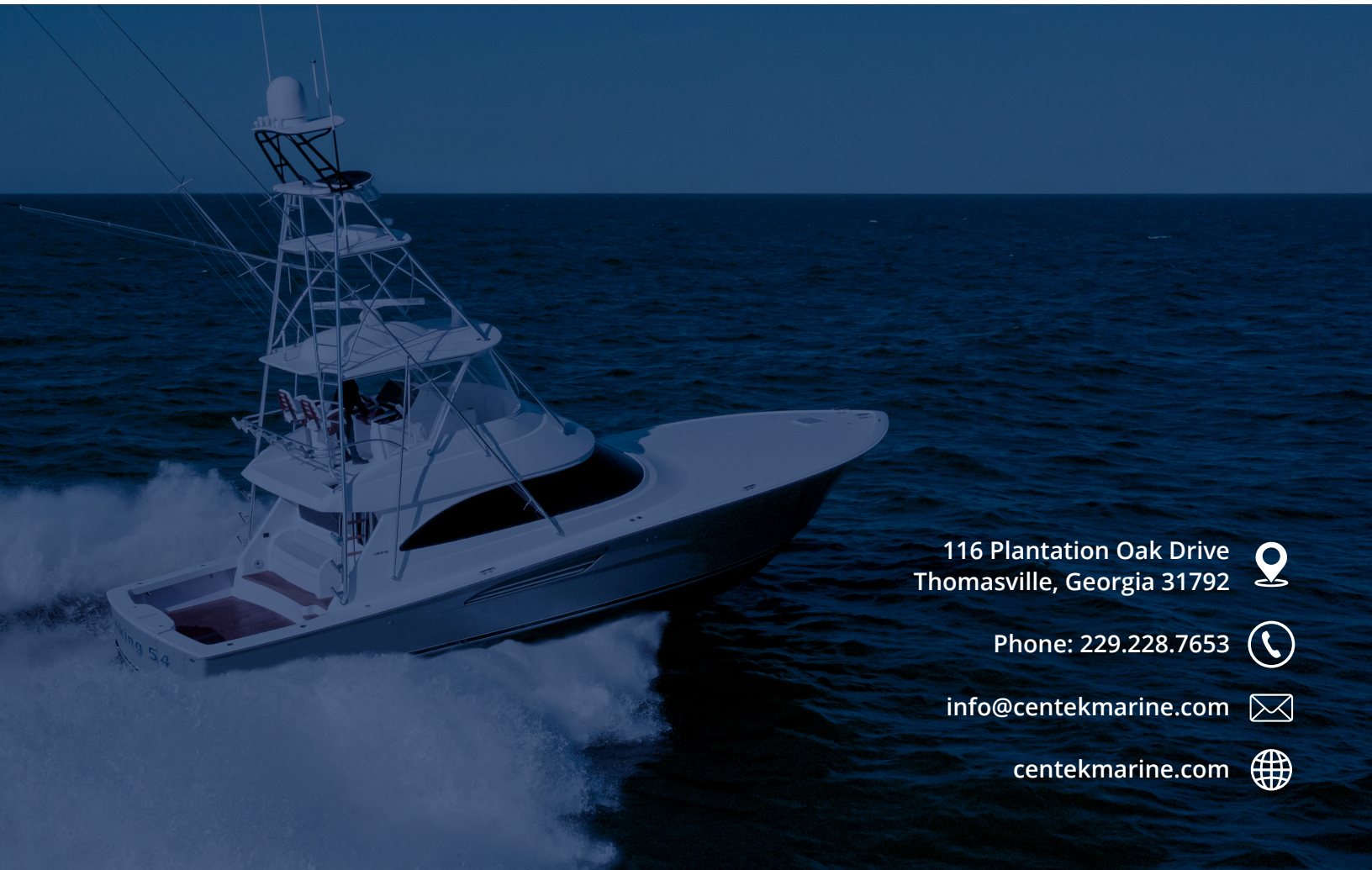

116 Plantation Oak Drive
Thomasville, Georgia 31792



Phone: 229.228.7653



info@centekmarine.com



centekmarine.com

